

RCA-215 - Truck

NonSteerable Auxiliary Axle Suspension

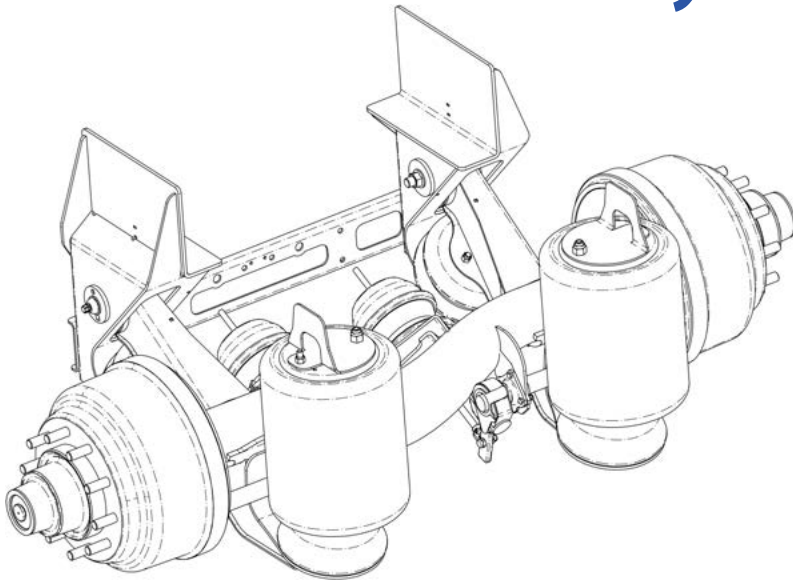

Installation and Service Manual

Suspension Identification	2
Axle Integration	3
Suspension Mounting	5
(Optional) Shock Absorber Installation	6
Air Control Kit (ACK) Components - Lifiable Axle	7
Maintenance	
Recommended Service Intervals	8
Drum Brake Suspension Components	
Disc Brake Suspension Components	9
Bushing Replacement Kits/Procedure	10
Axle Alignment	13
Air Tank Integration Kit	14
Air Spring (Load) Mounting Plate/Spacer	15
Suspension manufactured before OCT 2014	
Suspension manufactured OCT 2014 - FEB 2017	
Suspension manufactured after FEB 2017	
Warranty	16





PART NO:
SUSP. NO:
SERIAL NO:

GROSS AXLE WEIGHT RATING CERTIFICATION IS PER THE FINAL STAGE MANUFACTURER OR ALTERER.

THIS PRODUCT MAY BE COVERED UNDER ONE OR MORE PATENTS, ADDITIONAL PATENTS MAY BE PENDING.

www.ridewellcorp.com (800) 641-4122

Suspension Identification Tag

The (606-) Installation/Assembly Number is listed as the Ridewell Part Number when other system components are factory installed onto the suspension.

The Suspension Number and Serial Number on the Suspension ID Tag refer to the model and the date of manufacture of an individual suspension system.

Please refer to the part number/suspension number and serial number when contacting us for customer service, replacement parts or warranty information.

NonSteerable Lift-Axle Operation

Raising nonsteerable lift axles is recommended before turning a corner, especially when navigating a sharp corner. A non-steerable axle that is not lifted when turning will scrub concrete/asphalt; cause premature wear/possibly damage the tires; and impose a high lateral stress on wheel/chassis vehicle components.

Raising the non-steerable lift-axle decreases tire wear, reduces maintenance costs, and ensures the proper functioning of the liftable-axle.

Operators should be aware of the wide variety of federal, state and local regulations that apply to the lifting of axles. If lifting is prohibited, it may be best to configure a steerable lift-axle for the vehicle.

Notes and Cautions

Read through entire Installation and Service Manual (ISM) before performing any installation/maintenance.

All work should be completed by a trained technician using the proper tools and safe work procedures.

The ISM uses two service note types to provide important safety guidelines. The service notes are defined as:

“NOTE:” Provides additional instructions or procedures to complete tasks and ensure the suspension and components function properly.

CAUTION Indicates a hazardous situation or unsafe practice that, if not avoided, could result in equipment damage and serious injury.



MODEL:		PART NO.	
SERIAL NO.		CAPACITY	TON

Axle-Body Identification Tag

The Base-Axle Part Number (165-) and the Serial Number refer to Ridewell-branded round axles manufactured in assorted wall thicknesses and track-widths.

Prior to Installation

Refer to the engineering drawing to view available ride heights and confirm dimensional requirements. Operating the suspension outside of design parameters can result in improper performance, damaged equipment, and void the warranty.

The methods and procedures listed in this manual are considered to be general practices. Installations can vary and procedures should be adapted, as needed.

- The Gross Axle Weight Rating (GAWR) is determined by the system component with the lowest load rating. Please consult with tire, wheel, axle and brake manufacturers before installation to determine the GAWR.
- If vehicle chassis modifications are required, consult with the vehicle manufacturer to ensure that such changes are permitted.
- Welding or altering suspension components is not permitted without the express written permission of Ridewell Suspensions.

Installer Responsibilities

The suspension installer has sole responsibility for proper attachment of the system to the vehicle chassis.

- The installer is responsible for locating the suspension system on the vehicle to provide the proper load distribution.
- The installer must verify that vehicle crossmembers are positioned to support the suspension.
- It is the installer’s responsibility to determine that axle spacing conforms to any applicable federal and local bridge laws.
- The installer must verify that air reservoir volume requirements are met after suspension installation. Consult the vehicle manufacturer or Federal Motor Vehicle Safety Standards (FMVSS) 121.
- The installer must verify there is sufficient clearance for proper functioning of the auxiliary suspension, air springs, brake chambers, steering components, axle (including axle to driveline clearance) and tires.

Axle Integration

Suspension systems are available with and without a factory integrated straight- or drop-axle.

Customer-supplied axle assemblies must be positioned and oriented (rotated) properly before welding the axle. The axle assembly should be installed so that the camshafts, when activated, rotate in the same direction as the wheels.

Use the top-center mark on straight-axes, if available, to identify the center of the axle and orient the axle assembly on the suspension.

CAUTION Failure to follow procedures and design specifications could result in injury, damage to the axle or suspension and void the warranty.

Weld Preparation

The joint to be welded should be positioned in the flat or horizontal position. All grease, dirt, paint, slag or other contaminants must be removed from the weld joint.

The axle and suspension components should be at a minimum temperature of 60°F (15.5°C). Pre-heat the weld zone to the axle manufacturer's recommended pre-heat temperature, if required.

Weld Procedure

- Center the axle assembly on the beams (Figure 1).
- Check the engineering drawing for the brake component orientation (rotation) before clamping into place and making the final welds.
 - Drum brake camshafts are spaced off the tail of the trailing arm beam. Make sure the brake chamber brackets are oriented properly and clamp the axle assembly into place.
 - Disc brake assemblies have a right- and left-hand caliper assembly. Make sure the callipers are located on the correct side and rotated to the proper position before clamping the axle assembly into place.
- Check the gap between the axle and the axle seats before welding (Figure 2). Side gaps should be no greater than 1/8". The gap at the bottom of the axle seat should be no greater than 1/16".
- Weld the axle to the seat according to Ridewell Weld Process #1 (Page 4).

NOTE: Mounted air springs should be covered to protect them from welding spatter.

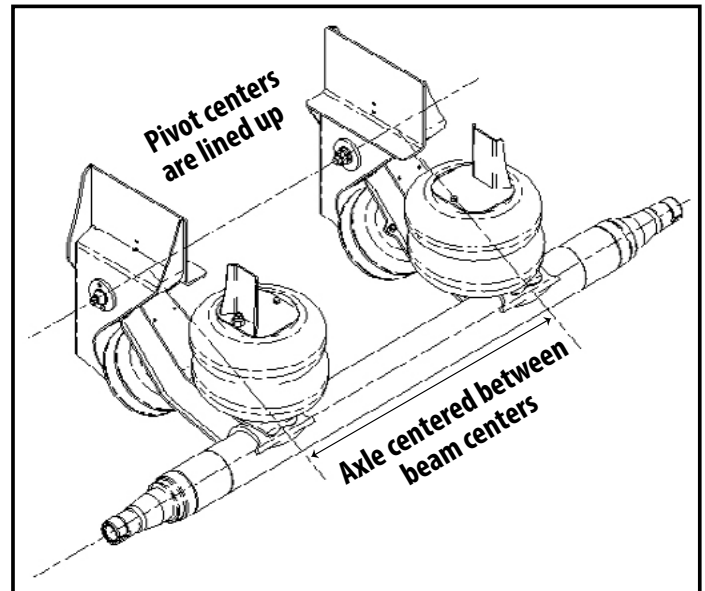

Figure 1.
Axle should be centered between beams.

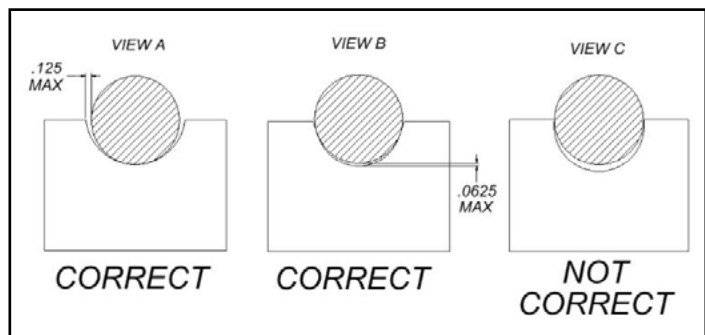
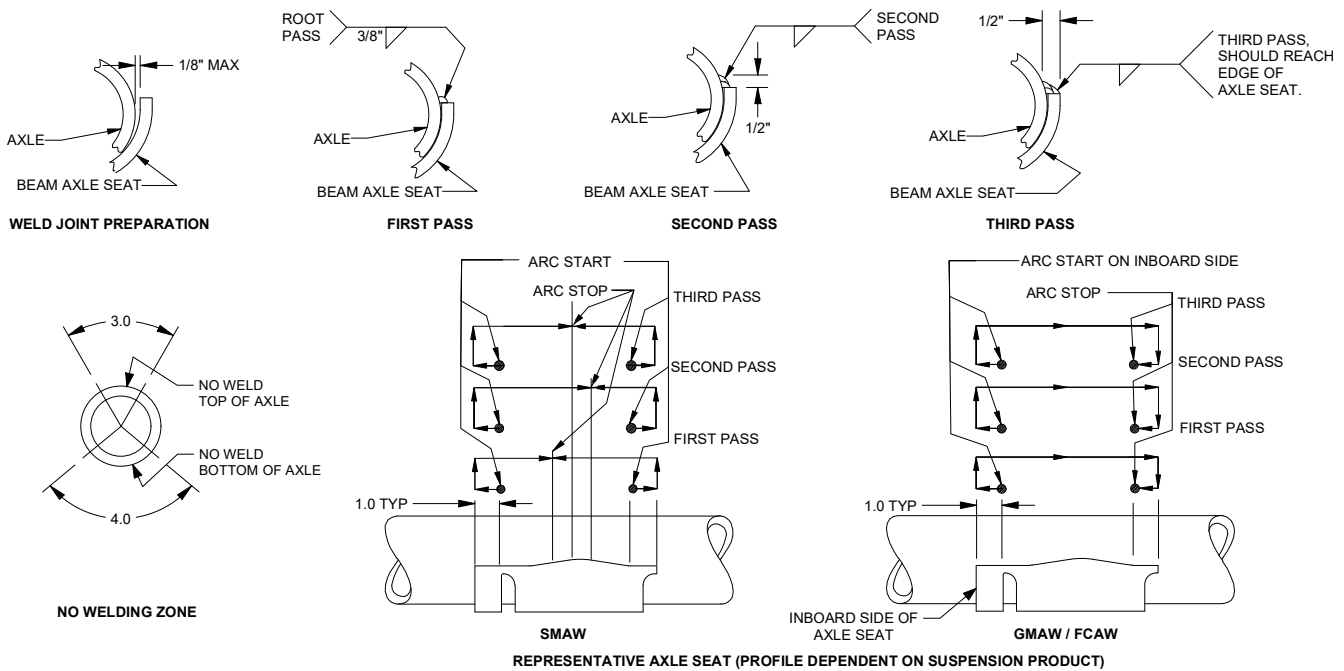
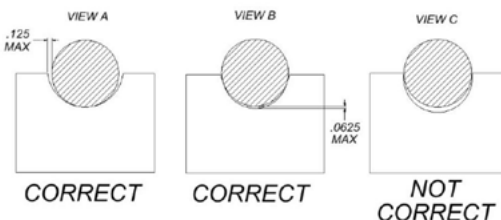

Figure 2.
Positioning axle for welding to axle seat.



- CAUTION:** All welds must be kept away from the top and bottom of the axle where maximum stresses occur (see "NO WELDING ZONE" illustration above). Do not test-weld the arc on any part of the axle tube.
- All welders and welding operators should be certified as per the requirements of the American Welding Society (AWS) or equivalent. All electrodes used should meet the AWS specifications and classifications for welding carbon and low-alloy steels.
- Recommended Welding Methods:** Shielded Metal Arc Welding (SMAW), Gas Metal Arc Welding (GMAW) or Flux Cored Arc Welding (FCAW). The welding method used and the electrode selected must develop a minimum weld tensile strength of 70,000 psi per AWS specifications. The best fusion and mechanical properties will be obtained by using the voltage, current, and shielding medium recommended by the electrode manufacturer. If the SMAW method is used, the stick electrodes must be new, dry, free of contaminants and stored per AWS specifications.
- Weld Joint Preparation:** The joint to be welded should be positioned in the flat or horizontal position. All grease, dirt, paint, slag or other contaminants must be removed from the weld joint without gouging the axle tube. It is recommended that paint be removed a minimum of 2" away from the weld joint. **CAUTION:** Never weld when the axle is cold. The axle and beam assemblies to be welded should be at a temperature of at least 60°F (15°C). Pre-heat the weld zone to the axle manufacturer's recommended pre-heat temperature, if required. This will reduce the chance of an area of brittle material forming adjacent to the weld.
- The axle should fit into the beam assembly with a maximum root gap of 1/8-inch between the axle and the beam axle seat (see "WELD JOINT PREPARATION" illustration above). The root gap should be as equal as possible on each side of the beam axle seat. The axle must be centered laterally in the beams.
- NOTE:** Clamp the axle to the beam axle seat with a C-clamp prior to welding to make sure that proper contact occurs (see "CORRECT" illustration below).
- Ground the axle to one of the attached axle parts such as the brake chamber brackets, cam brackets or brake spider. Never ground the axle to a wheel or a hub as the spindle bearing may sustain damage.
- Multiple pass welding should be used on the beam/axle connection using the following guidelines:**
 - Total fillet weld size should be 1/2-inch.
 - Weld pass starts and stops should be performed as illustrated above.
 - Never start or stop welds at the end of the weld joint.
 - Each pass must be accomplished in one or two segments.
 - Start welds at least 1-inch from the end and backweld over the start. Backstep fill all craters.
 - If process is not GMAW all slag must be removed between passes.
 - Welds must go to within 1/8-inch +/- 1/16-inch of the ends of the axle seat and must not go beyond or around the ends of the axle seat.
 - Post-weld peening is recommended, but not required: Needle peen the entire toe of the second pass, including around the ends of the axle seat. Hold the needles perpendicular to the axle. A uniform dimpled pattern will appear when properly peened.



J	23101	ADDED 9710039 TO DRAWING NUMBER	11/13/23	AAS	BB	CJB
REV	PROJ/ECR	DESCRIPTION	DATE	BY	CHK	APPD
DRAWN BY:	CBC	11/13/2023	RIDEWELL CORPORATION PO BOX 4586 SPRINGFIELD, MISSOURI 65808			
CHECKED:	MDJ	2/21/2003				
APPROVED:	CJB	2/21/2003				
PROJECT NO:	03103	SCALE: A-SIZE: NTS	TITLE: RIDEWELL WELD PROCESS #1, 5" DIA. AXLE, 3 PASS WELD			
MATERIAL:	-	WEIGHT:	SHEET 1 OF 1			
			PART NO:	9710039-WELD PROCESS No1		REV: J

UNCONTROLLED IF PRINTED

Suspension Mounting

Refer to the engineering drawing for the suspension travel table; mandatory customer-supplied crossmember locations; recommended mounting bolt-hole locations; and, the suspension spacing and clearance requirements.

CAUTION Suspension components must be reassembled with proper torque applied if the suspension is taken apart for installation (Page 10).

Do not apply any undercoating; paint or other top coat to the suspension, frame hangers or pivot hardware until axle alignment is completed.

NOTE: Areas where metal surfaces of alignment plates; washers; pivot bolts/nuts or pivot bushing (bushing sleeve) contact the frame hanger must be masked if applying under- or top coating prior to suspension assembly (Figure 3).

Bolt-On Installation Procedure

Grade-8 bolts, flanged locknuts or locknuts with hardened washers for suspension mounting are supplied by the installer.

NOTE: The hanger crosschannel should be installed after axle integration. Torque locknuts to 45-50 ft-lb.

An optional shock absorber kit can be installed after the suspension is mounted (Page 6).

Suspension ride height is adjusted with a 1" or 2" spacer kit (Page 15).

1. Locate hanger/air spring mounting plates/spacers on the chassis and clamp firmly into place.

CAUTION Corresponding hanger mounting spacer must be installed with the air spring spacer. All Hangers/Mounting Plates/Spacers must have full contact with the bottom of the vehicle frame.

2. Confirm hangers/mounting plates/spacers are evenly located and square to the frame. Verify the location provides adequate clearance for the assembled suspension components.

3. Center-punch and drill eight bolt-holes (min 5/8") in each frame hanger. Center-punch and drill two bolt-holes (minimum 5/8") in each air spring mounting plate.

NOTE: Space the bolt-holes for mounting as far apart as possible if the recommended bolt-hole locations are not available.

CAUTION Check to make sure that wires, hoses or other components located within the chassis are not affected by drilling the bolt-holes.

4. Bolt suspension assembly to vehicle chassis with 5/8" Grade 8 bolts and locknuts.

5. Attach the load springs to the air spring mounting plates. Torque to specifications (Page 10).

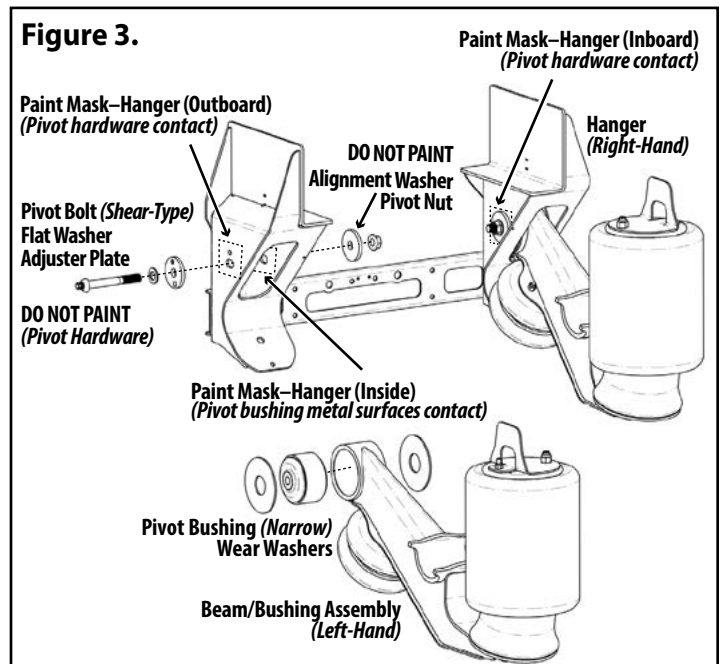

6. Install/connect the air control kit (ACK). Check the air system after installation for leaks (Page 7).

7. Perform final assembly and inspection and align the suspension per TMC or SAE recommended standards. Alignment should be performed with suspension at installed ride height (Page 13).

Final Assembly and Inspection

1. Verify that all suspension components are torqued to specifications (Page 10).

2. Install wheels and tires.

CAUTION When lowering an auxiliary axle on an unloaded vehicle, pressure to the load air springs must be reduced to below 10 psi.

Failure to reduce the air pressure could cause the vehicle's drive axles to rise from the ground and the vehicle could roll in an unsafe manner.

3. Check that tires are inflated to the recommended pressure. Check wheel hubs for the proper level of lubricant as recommended by the manufacturer.

4. Lift the axle to the raised position. Check the air system tubing and connections for leaks.

5. Check that wheels can rotate freely and that brakes are properly adjusted.

6. Raise and lower the suspension assembly through the entire range of travel. Check for sufficient vehicle clearances of air springs, brake chambers and other components.

CAUTION Do not lower the auxiliary axle while the vehicle is moving above 10 mph.

(Optional) Shock Absorber Installation

Refer to the shock absorber kit engineering drawing for the mounting locations and the upper and lower mounting bracket installation angles.

CAUTION The welding method for the mounting bracket must use a minimum weld tensile strength of 70,000 PSI, per AWS specifications.

Shock Absorber Installation Procedure

1. Disconnect and remove load springs from the suspension assembly.
NOTE: Protect lift springs from welding spatter.
2. Locate and drill three holes in the chassis above the air spring mounting plate for the upper mounting bracket. Bolt bracket to the chassis with customer-supplied Grade 8 bolts and locknuts (5/8" recommended).
NOTE: The upper brackets' installation height needs adjustment if the hanger/air spring spacers are installed.
Rotate the brackets to allow the shock absorbers to clear the air spring mounting plates.
3. Measure the location of the shock absorber to the axle (lower) mounting bracket from the edge of the axle seat, not from the axle weld. Clamp the mounting bracket into place.
Use 5/16" fillet weld to weld the lower mounting bracket to axle at the forward and rear edge only. Do not weld perpendicular to the axle centerline.
4. Attach shock absorber to mounting brackets:
 - 4.1. Attach shock absorber to upper mounting bracket with Hex Head Cap Screw (HHCS) and flat washer.
Torque HHCS to 160-200 ft-lb (217-271 N-m).
 - 4.2. Attach shock to lower mounting bracket with HHCS and locknut.
Torque locknut to 160-200 ft-lb (217-271 N-m).
5. Install load springs. Torque to specifications (Page 11). Connect load springs to air system.
6. Raise and lower the suspension to make sure that shock absorbers clear the air spring mounting plates and do not overextend during travel.

CAUTION Failure to torque suspension components to specifications can result in failure of the suspension and void the warranty

Regulate load with air spring pressure

The load capacity of the auxiliary axle is adjusted by increasing or decreasing the pressure to the air springs. By applying more air, the lift axle takes on a greater percentage of the load's weight. The load capacity is decreased as the air pressure decreases.

Accurate readings of the load capacity can be obtained by parking a loaded vehicle over a calibrated scale and lowering the axle onto the scale. The air pressure to the air springs is manually adjusted up or down to obtain the axle load weight at various air pressures.

CAUTION Do not exceed rated load capacity of the suspension system or other components. Exceeding the capacity can cause component failure and void the warranty.

Air Control Kit (ACK) Components - Lifiable Axle

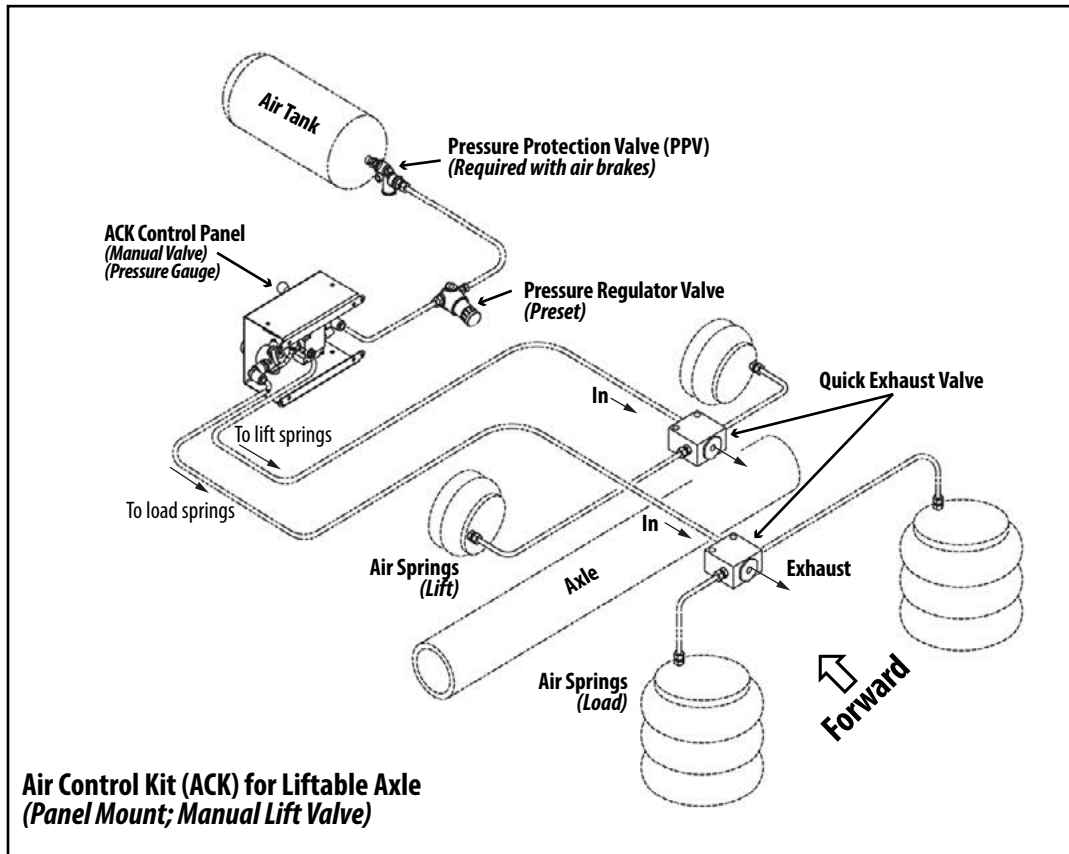

The air control kit consists of a pressure regulator with a gauge; connected to an air valve that is operator-controlled by a manual knob or by an electric switch.

The operator uses the air control kit to control the pressure to the air springs to support different loads.

Contact Ridewell Customer Service for the manual/electric ACK configurations available. Installation will vary by air control kit configuration.

CAUTION The installer is responsible for ensuring air system requirements comply with appropriate Federal Motor Vehicle Safety Standards.

Air Control Kit – Troubleshooting

Problem	Possible Cause	Solution
Air springs fill but do not exhaust.	<ul style="list-style-type: none"> – Obstructed air line. – Faulty controls wiring. – – Manual override pushed in. 	<ul style="list-style-type: none"> – Check for pinched/blocked lines. – Check controls wiring with voltmeter. Correct wiring/installation. – Release manual override.
Air system leaks down after a short period of time.	<ul style="list-style-type: none"> – Leak in air system beyond accepted standards. NOTE: Some valves will leak at an acceptable rate. 	<ul style="list-style-type: none"> – Pressurize system. Spray soapy water solution onto the tubing, valves and fittings. Check for bubbles (leaks). – Check that tubing cuts are straight and smooth. Re-cut and reassemble fitting joints, if necessary.
Auxiliary unit will not stay up	<ul style="list-style-type: none"> – Loose air fitting connection/Damaged air lines. – Air lines to lift and load air springs are reversed. – Damaged or worn air springs. 	<ul style="list-style-type: none"> – Check and retighten fittings. Repair or replace component, as necessary. – Check installation. Air line from regulator goes to (load) air springs. – Replace air spring if worn or damaged.
Auxiliary unit not achieving correct lift	<ul style="list-style-type: none"> – Air lines to lift and load air springs are reversed. – Lift air springs do not have proper air pressure. – Interference with driveline/other chassis components. – Air control system not installed correctly. 	<ul style="list-style-type: none"> – Check installation. Air line from regulator goes to (load) air springs. – Check for loose fittings or worn/damaged lines. Verify air tank pressure with gauge. – Visually inspect auxiliary unit operation for proper clearance. Retighten any loose fasteners. – Check air control kit installation; refer to OEM installation procedures.

Recommended Service Intervals

Ridewell Suspensions recommends these minimum service intervals for standard duty, on-highway usage applications. More frequent intervals are recommended for heavier duty applications.

Daily/Pre-Trip Inspections

- ___ Check tires for proper inflation, damage or excessive wear.
- ___ Check wheel-ends for obvious signs of lubricant leakage. Check for missing components.
- ___ Check axle assemblies for damage/loose components.
- ___ Visually inspect suspension structure for signs of damage or excessive wear.
- ___ Check for loose or missing bolts/nuts. Check for irregular movement in suspension components.
- ___ Make sure air controls are operating properly. Drain all moisture from air reservoirs.

First 6,000 miles of use

- ___ Torque components to specifications. (Page 10).
NOTE: Do not re-torque shear-type pivot bolt.
- ___ Verify that the suspension is operating at the designed ride height.

Refer to these Technology & Maintenance Council (TMC) publications for maintenance information

RP 609	Brake Adjuster Installation/Maintenance
RP 618	Wheel Bearing Adjustment Procedure
RP 619	Air System Inspection Procedure
RP 622	Wheel Seal and Bearing Removal, Installation, and Maintenance
RP 631	Recommendations for Wheel End Lubrication
RP 643	Air Ride Suspension Maintenance Guidelines
RP 728	Trailer Axle Maintenance

Every 12,000 miles of use

- ___ Inspect air springs for damage/excessive wear. Torque components to specifications (Page 10).
- ___ Check air lines and connections for leaks.
- ___ Lubricate Brake Cams and Slack Adjusters.

First 50,000 miles of use

- ___ Torque suspension components to specifications (Page 10).
NOTE: Do not re-torque shear-type pivot bolt.
- ___ Check wheel ends for excessive play.

Annually/100,000 miles of use

- ___ Inspect pivot connections for worn bushings. Replace, if necessary. Torque pivot hardware and component bolts/nuts to specifications (Page 10).
- ___ Check suspension hanger and air spring mounting plate connections to vehicle frame.

Check lubrication level in wheel ends:

- ___ 1) Oil-Filled: Refill/Replace lubricant as needed. (TMC RP 631 "100K/Annual Inspection").
- ___ 2) Semi-Fluid Grease: Pull outer bearing and visually inspect lubrication level. Refill/Replace as needed (TMC RP 631 "Level 3 Lubrication Level Inspection" (TMC RP 618 "Wheel Bearing Adjustment").
- ___ Check air system for leaks.
- ___ Test air system pressure protection valve (if equipped).
- ___ Check brake chambers and brakes for damage and proper function.

CAUTION Failure to torque bolts/nuts of suspension components to specifications can result in failure of the suspension and void the warranty.

Pivot Bushing Inspection Procedure

The pivot bushing can be checked without disassembling the suspension. Park the unloaded trailer on a level surface. Set the brakes and chock the tires so vehicle cannot move during inspection.

Insert the flat end of a pry-bar between one side of the hanger sidewall and the wear washers. Move the pry-bar back-and-forth and look for excessive movement of the beam (NOTE: A small amount of beam

movement because of the rubber flexing is normal). Inspect the wear washers for excessive wear/damage.

Repeat the pry-bar process and wear washer inspection on the other side of the hanger. If any large/easy movement or damaged wear washers is observed, drop the beams for further inspection. Replace components as necessary.

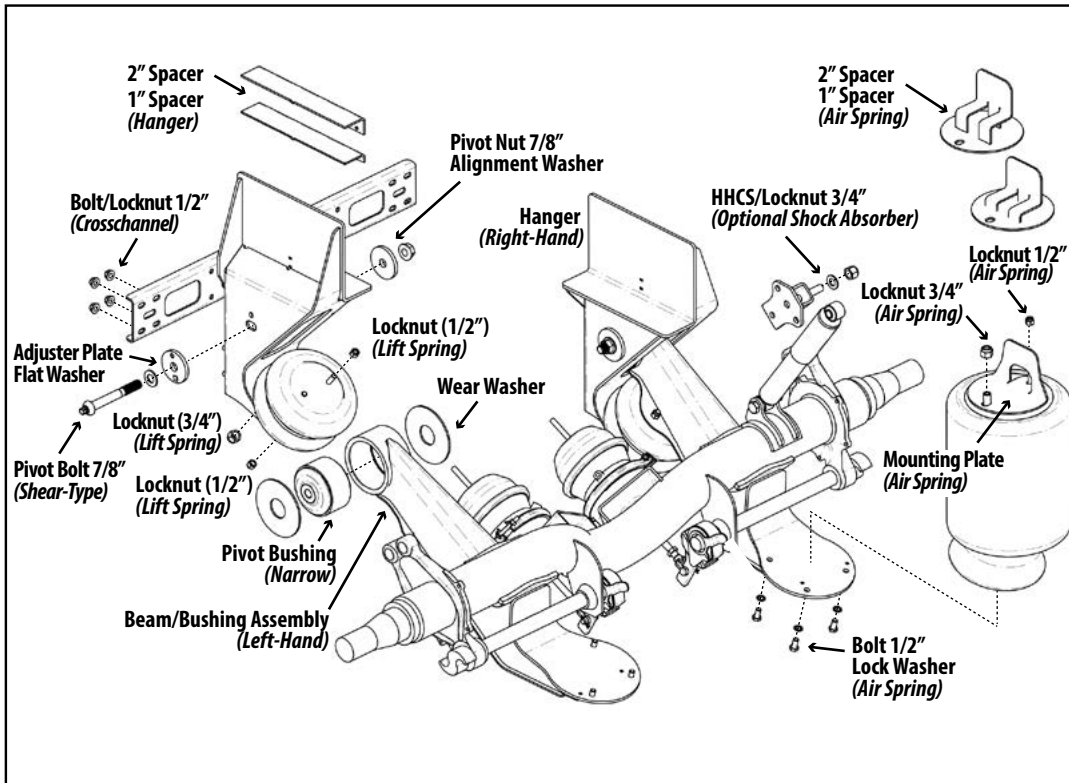

Figure 4.
Drum Brake
Suspension Components
215 Truck suspension
with integrated drop-axle
assembly shown.
Refer to the engineering
drawing for the individual
component part number.

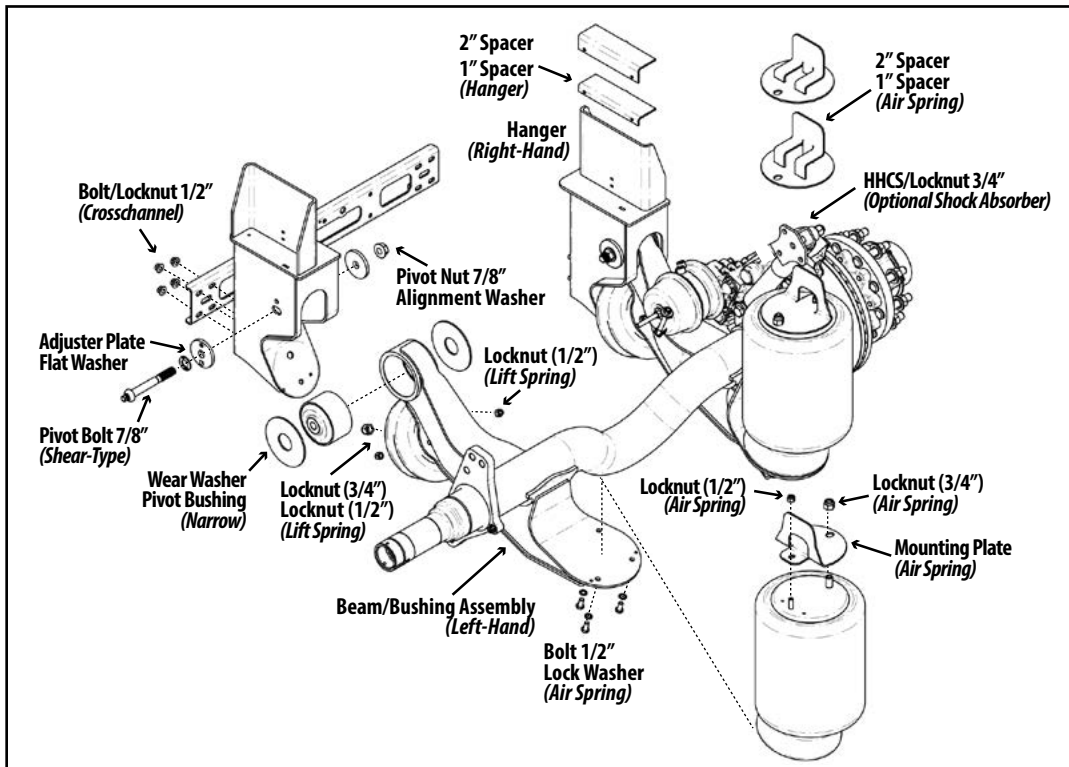

Figure 5.
Disc Brake
Suspension Components
215 Truck suspension
with integrated drop-axle
assembly shown.
Refer to the engineering
drawing for the individual
component part number.

RCA 215 TRUCK SUSPENSION — BUSHING REPLACEMENT KITS/BUSHING REPLACEMENT PROCEDURE

Part Number	Item Description	Size	Torque Values	
			foot-pound	Newton-meter
6040128-Bushing Kit Bushing Tool-6100044	Pivot Bolt (Shear-Type) <i>Requires E-20 Torx® socket (RW #6100054)</i>	7/8" -9NC	<i>Do not lubricate bolt/nut threads. Use 1" -drive impact wrench to tighten bolt until Torx® head shears off.</i>	
6040078-Bushing Kit Bushing Tool-6100044	Pivot Bolt - Hex Head Cap Screw (HHCS) Pivot Nut - (Locknut)	7/8" -9NC	500 ft-lb	678 N-m
Fasteners	Locknut - (Air Spring; Lift Spring)	1/2" -13NC	25 ft-lb	35 N-m
	Locknut - (Air Spring; Lift Spring)	3/4" -16NF	50 ft-lb	68 N-m
	Locknut - (Crosschannel)	1/2" -13NC	45-50 ft-lb	61-68 N-m
	HHCS/Locknut - (Optional Shock Absorber)	3/4" -10NC	160-200 ft-lb	217-271 N-m

Torque values reflect a lubricated thread condition (Nuts are pre-lubed). Do not overtorque.

CAUTION Suspension is shipped with minimal torque applied to fasteners. All fasteners must be re-torqued after first 6,000 miles of operation. Failure to install and maintain fasteners at torque specifications could result in suspension failure and void the warranty.

Vehicle Preparation

Park vehicle on a level surface. Chock wheels to keep vehicle from moving.

Raise vehicle to a height that removes the load on the suspension. Support with jack stands.

Disconnect the linkage from the height control valve(s), if equipped. Exhaust all air from the system.

CAUTION Failure to properly chock wheels, exhaust the air system and safely support the vehicle could allow vehicle/suspension movement that could result in serious injury.

Disassemble the suspension

Remove wheels and tires, if necessary. Remove the shock absorbers (if equipped).

Take the pivot connections apart. Remove and discard pivot bolt, flat washer and pivot nut. Inspect adjuster plate and alignment washer for wear/damage. Replace if necessary.

CAUTION Do not reuse pivot hardware.

Rotate beams down and away from frame. Inspect pivot-bolt holes and wear washers for unusual wear/damage. Repair or replace components as needed.

continued on next page

P/N 6100044
Narrow Bushing Replacement Tool

No.	Part No.	Item Description
1	1130088	HEX HEAD CAP SCREW (HHCS) 7/8"-6; 18" GR5
2	1160036	FLAT WASHER — 7/8" F436 ZINC COATED
3	1120051	BEARING COLLAR
4	1660009	THRUST BEARING
5	6100089	ENDCAP — NARROW BUSHING TOOL
6	6100092	CONE ASSEMBLY — NARROW BUSHING TOOL
7	6100091	PLUNGER — NARROW BUSHING TOOL
—	1980014	EXTREME PRESSURE LUBRICANT

Replacement Procedure with Narrow Bushing Tool #6100044 (continued)

Tool Assembly

Check that thrust bearing is installed in the flat, outside edge of endcap. Inspect tapered insert and endcap for damage. Repair or replace as needed.

Lubricate Hex-Head Cap Screw and thrust bearing threads with Extreme Pressure Lubricant (#1980014).

Thread the flat washer, the bearing collar and the endcap onto the HHCS until the bearing collar and endcap rest against the head of the HHCS. Place tool cone onto endcap (Figure 6).

NOTE: Failure to apply lubricant to the threads could result in decreased tool performance and reduce the life of the bushing tool.

Bushing Removal

1. Push the HHCS through the inner sleeve until the tool cone is against the beam eye. Thread the plunger onto the HHCS until the tool cone is held firmly against the beam (Figure 6).

NOTE: Tapered end of cone is placed against the beam eye for both removal and installation.

2. Check that tool cone is centered on the beam eye. Use a 1 5/16" socket on a 3/4"-drive impact wrench (1"-drive impact wrench recommended) to rotate HHCS and pull the bushing into cone.

NOTE: In some cases, a small amount of heat may be needed to break the bond between the bushing and beam eye.

Do not overheat. Allow the beam to cool before installing replacement bushing.

3. Remove bushing tool from the beam. Detach tool cone from endcap, remove bushing and discard.

continued on next page

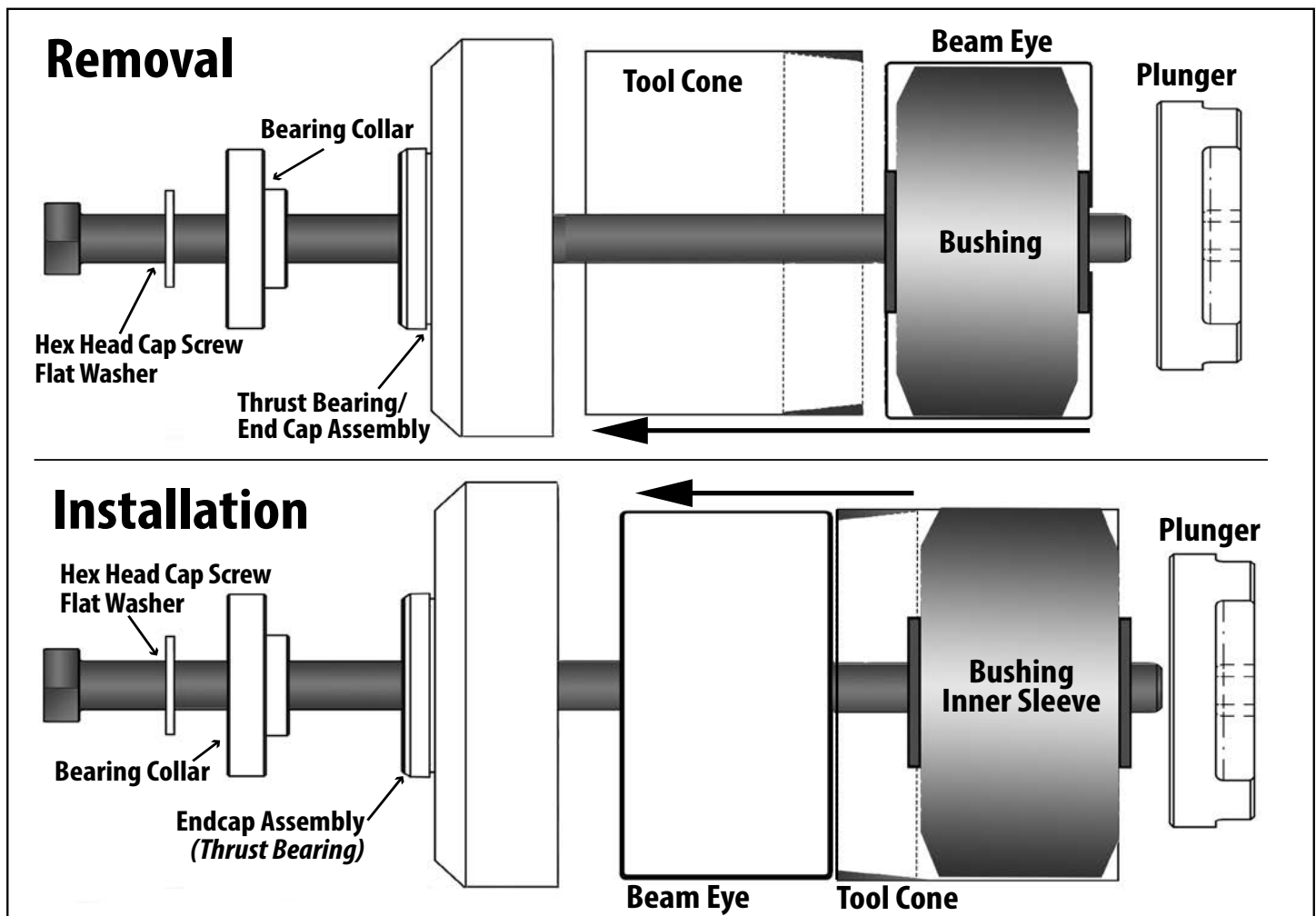

Figure 6.

Place tapered end of cone against beam eye for bushing installation and removal.

Replacement Procedure with Narrow Bushing Tool #6100044 (continued)

Tool Assembly

Thread the flat washer, the bearing collar and the endcap onto the hex-head cap screw until the bearing collar and endcap rest against the head of the HHCS.

Bushing Installation

1. Use wire brush to clean debris /corrosion from eye.
2. Liberally apply P80[®] lubricant or a soap solution to the inside of the beam eye, the outside of the new bushing and inside the tool cone. Insert replacement bushing into the larger opening of the tool cone (Figure 7).
3. Center the smaller opening of the tool cone against beam eye. Push the hex-head cap screw through the bushing inner sleeve from the opposite side of the beam until the endcap rests against the beam eye.
4. Thread the plunger onto the hex-head cap screw until tool cone is held firmly against the beam.
NOTE: The smaller opening of the tool cone is placed against the beam eye for both removal and installation of the bushing.
5. Verify that bushing tool cone is centered on the beam eye. Use a 1 5/16" socket and 3/4"-drive impact wrench (1"-drive impact wrench recommended) to rotate the hex-head cap screw and press the bushing into the beam eye.
6. Disassemble and remove bushing tool from the beam. Verify bushing is centered inside the beam. Realign bushing if necessary.

Reassemble suspension

Rotate the beams into hangers.

Assemble the pivot connection – alignment washer, adjuster plate, wear washers, shear-type pivot bolt, flat washer and flanged locknut.

NOTE: Do not lubricate pivot bolt/nut.

Tighten locknut until adjuster plate pin is engaged and pivot connection hardware is snug against the hanger. Do not apply final torque until the axle alignment has been checked.

Install the shock absorbers (if equipped).

Connect the height control valve linkage (if linkage has been disconnected). Inflate air springs.

Install wheels and tires (if removed). Raise the vehicle and remove support stands. Lower vehicle to ground.

Verify the suspension ride height. Check axle alignment. Realign if necessary (Page 13).

Tighten pivot bolt with a 1" drive impact wrench and E-20 Torx[®] socket (Ridewell tool #6100054) until Torx[®] head is sheared off.

CAUTION Failure to torque hardware to specifications can result in suspension failure/void the warranty.

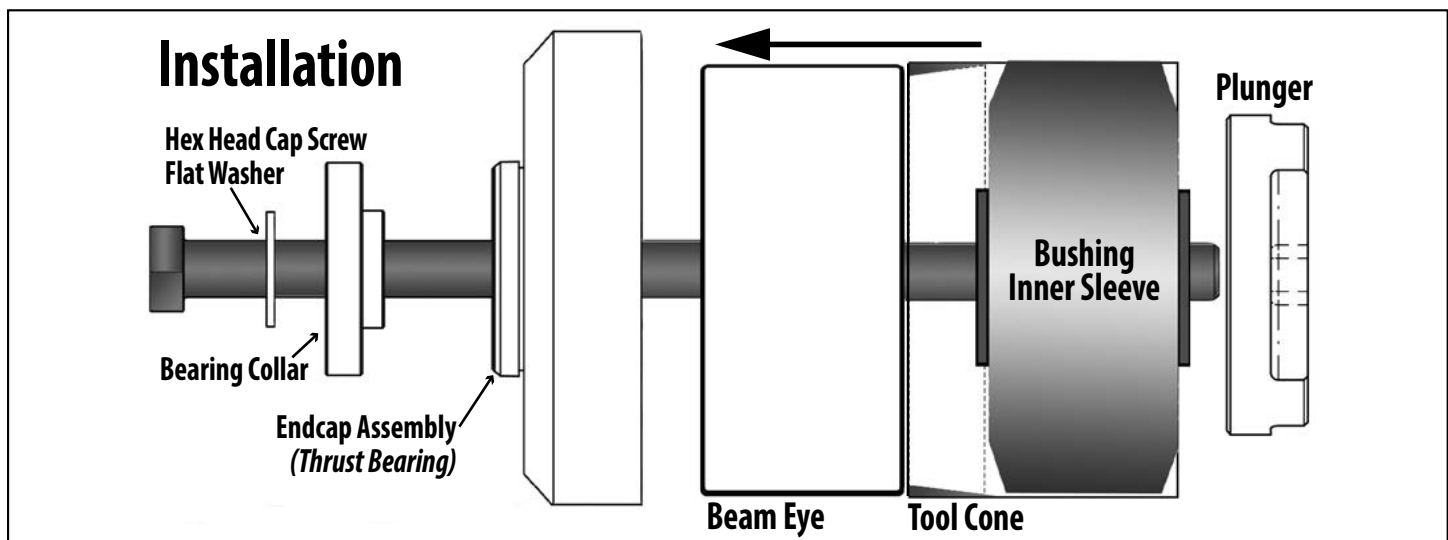

Figure 7.
Place the tapered end of the cone against the beam eye for bushing installation and removal.

Axle Alignment

Alignment should be performed on a level surface with the suspension at the desired ride height. Align the suspension per TMC- or SAE-recommended standards.

On a multiple-axle vehicle, the forward axle is moved into proper alignment, then the remaining axles are positioned so that they are parallel to the forward axle. A maximum tolerance of 1/8-inch difference from side-to-side of the forward axle and 1/16-inch difference from side-to-side for the aft axles is acceptable (Figure 8).

The RCA 215 Suspension is equipped with the Ridewell Speed Set® alignment feature for manual alignment.

Figure 8. Kingpin measurement for axle alignment.

Check the forward axle alignment by measuring from the kingpin to both ends of the axle centers.

If the difference between the "A" measurement and the "B" measurement is greater than 1/8-inch, the forward axle needs to be aligned.

Adjust the aft axle if the difference between the "C" measurement and the "D" measurement is greater than 1/16-inch.

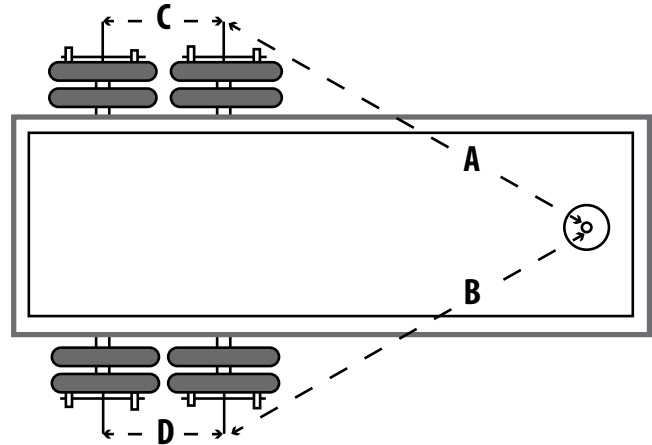

Axle alignment procedure

1. Loosen the pivot nut enough for the beam to move within the hanger (Figure 9).
CAUTION Do not reuse pivot hardware if Torx® head is damaged or missing. A new shear-type pivot bolt, flat washer and locknut must be installed and the Torx head sheared off to complete the alignment.
2. Locate the adjuster plate at the pivot connection. Insert a 1/2"-shank breaker bar into the square hole of the adjuster plate. Push on the breaker bar to move the beam forward or backward until the axle reaches alignment measurements (Figure 9).
NOTE: Verify the pivot bushing is not wedged sideways during beam movement. The adjuster plate and alignment washer should move in unison with beam movement.
3. Tighten the pivot nut so that the beam can no longer move. Re-check alignment measurements and adjust if necessary.
NOTE: Check to make sure both the adjuster plate and alignment washer are flat against the hanger before final torque is applied.
4. Tighten pivot bolt with a 1"-drive impact wrench and E-20 Torx® socket (Ridewell tool #6100054) until the Torx® head is sheared off.

CAUTION Failure to properly torque pivot hardware could result in suspension failure and void the warranty.

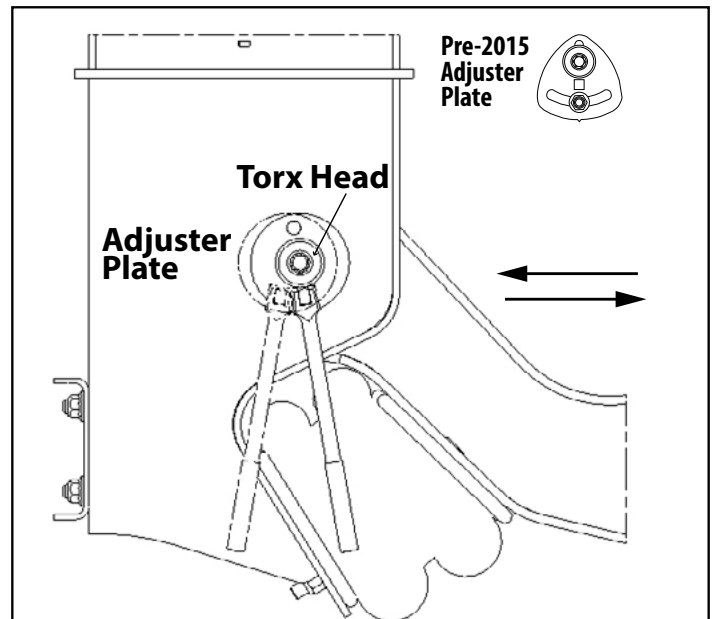

Figure 9.
Move beam back-and-forth using breaker bar until the axle reaches the desired position.

Air Tank Integration Kit (*Factory Preplumbing Available)

Part Number	Part Number- *Preplumbing	Item Description	Air Tank: 2200-Cu In	(PPV) Pressure Protection Valve	(LACM) Lift Axle Control Module	Brake Relay Valve	(QE) Quick Exhaust Valve
1200250	1200251	LACM Kit – Drum Brake Drop-Axle* <i>*Requires integrated axle. Install valves, fittings, air lines from air tank to air springs.</i>	1230254	1230060	1230195	1230081	
1200290	1200291	LACM Kit – Disc Brake Straight-Axle*/Drop-Axle* <i>*Requires integrated axle. Install valves, fittings, air lines from air tank to air springs.</i>					
1200264	1200265	LACM Kit – Drum Brake Straight Axle* <i>*Requires integrated axle. Install valves, fittings, air lines from air tank to air springs.</i>					
1200281	1200282	Quick Exhaust (QE) Valve Kit – Drum Brake Drop-Axle* <i>*Requires integrated axle. Install valves, fittings, air lines from air tank to air springs.</i>					1230078 <i>(2) valves needed</i>

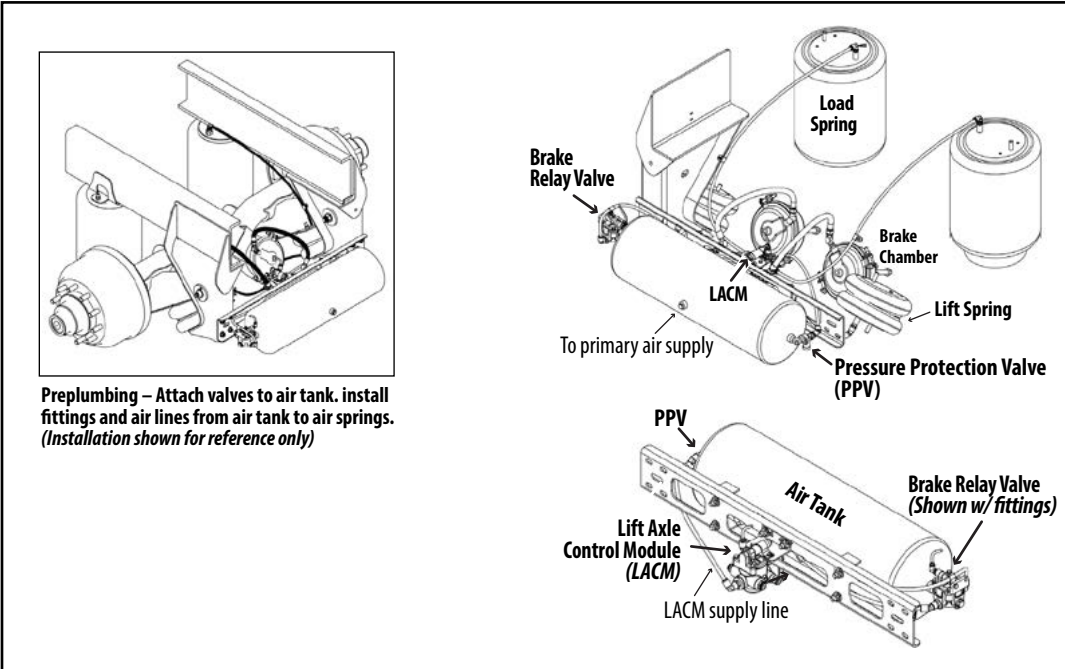

Figure 10.
1200250-LACM Kit shown
(Preplumbed reference only)

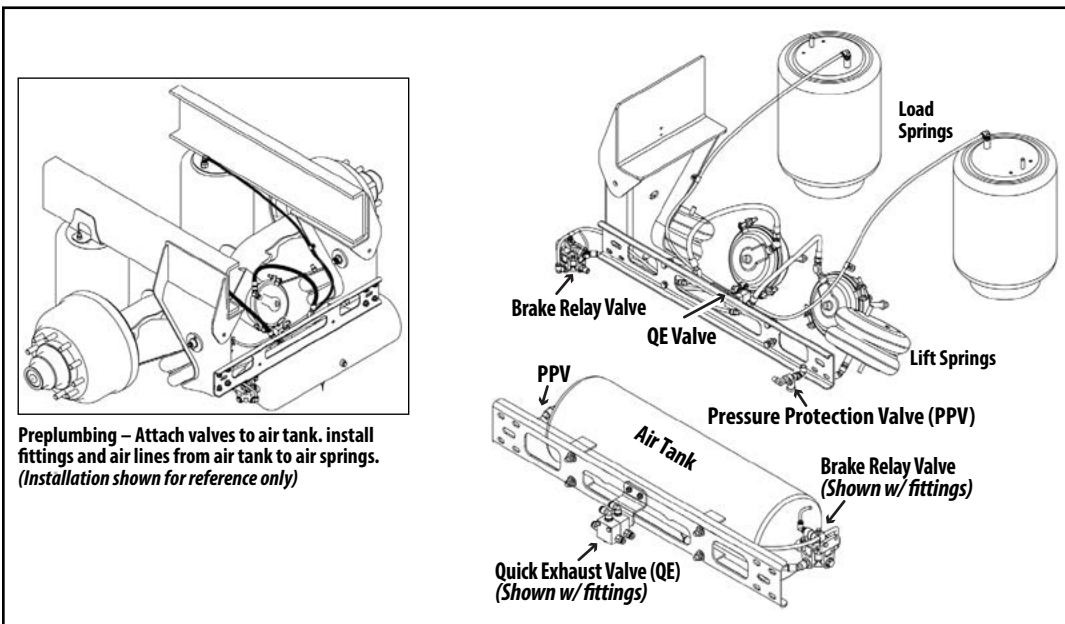
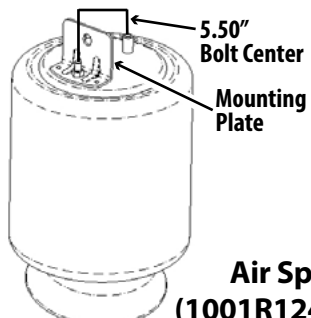
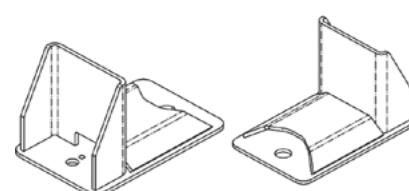
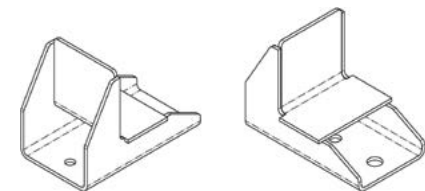

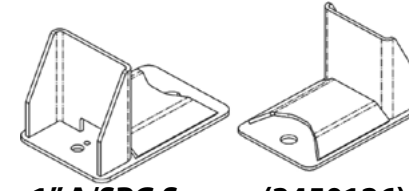
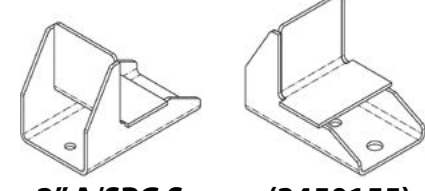
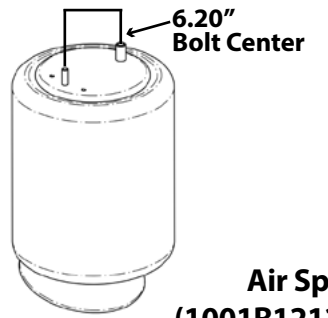
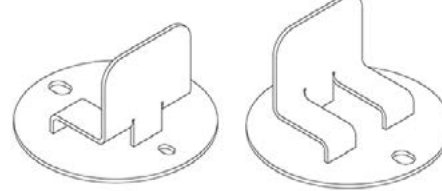
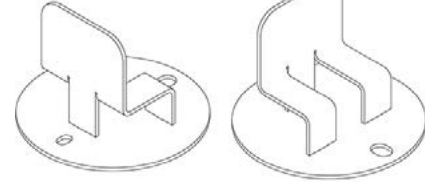

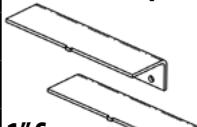



Figure 11.
1200281-QE Valve Kit shown
(Preplumbed reference only)

RCA-215 TRUCK SUSPENSION – AIR SPRING (LOAD) MOUNTING PLATE/SPACER (VARIES BY SUSPENSION DATE OF MANUFACTURE)

<p>Suspension manufactured before OCT 2014</p>  <p>5.50" Bolt Center Mounting Plate</p> <p>Air Spring (1001R12444)</p>	<p>Mounting Plate (5.50" Bolt Center) <i>Included with Air Spring</i></p>  <p>1" A/SPG Spacer (3450126)</p>  <p>2" A/SPG Spacer (3450155)</p>	
<p>Suspension manufactured OCT 2014 - FEB 2017</p>  <p>5.50" Bolt Center</p> <p>Air Spring (1001R12653G)</p>	<p>Mounting Plate (5.50" Bolt Center) (3450154)</p>  <p>1" A/SPG Spacer (3450126)</p>  <p>2" A/SPG Spacer (3450155)</p>	
<p>Suspension manufactured after FEB 2017</p>  <p>6.20" Bolt Center</p> <p>Air Spring (1001R121202)</p>	<p>Mounting Plate (6.20" Bolt Center) (8003809)</p>  <p>1" A/SPG Spacer (3450266)</p>  <p>2" A/SPG Spacer (3450267)</p>	

215 Truck – Hanger spacer must be installed at the same time as air spring spacer

Component	Part Number	Item Description
 <p>2" HGR Spacer</p>	6040167 (Drum)	1" SPACER KIT (6.20" Bolt Center) – Hanger; Air Spring Spacer
	8001811	1" Hanger Spacer
 <p>1" Spacer</p>	6040168 (Drum)	2" SPACER KIT (6.20" Bolt Center) – Hanger; Air Spring Spacer
	8001812	2" Hanger Spacer
 <p>2" HGR Spacer</p>	6040169 (ADB)	1" SPACER KIT (6.20" Bolt Center) – Hanger; Air Spring Spacer
	8003434	1" Hanger Spacer
 <p>1" Spacer</p>	6040170 (ADB)	2" SPACER KIT (6.20" Bolt Center) – Hanger; Air Spring Spacer
	8003435	2" Hanger Spacer

Terms and coverage in this warranty apply only to the United States and Canada.

Ridewell Suspensions warrants the suspension systems manufactured by it to be free of defects in material and workmanship. Warranty coverage applies only to suspensions that have been properly installed, maintained and operated within the rated capacity and recommended application of the suspension. The responsibility for warranty coverage is limited to the repair/replacement of suspension parts. The liability for coverage of purchased components is limited to the original warranty coverage extended by the manufacturer of the purchased part.

All work under warranty must have prior written approval from the Ridewell warranty department. Ridewell has the sole discretion and authority to approve or deny a claim and authorize the repair or replacement of suspension parts. All parts must be held until the warranty claim is closed.

Parts that need to be returned for warranty evaluation will be issued a Returned Materials Authorization (RMA). Parts must be returned to Ridewell with the transportation charges prepaid. The transportation charges will be reimbursed if the warranty claim is approved.

This non-transferable warranty is in lieu of all other expressed or implied warranties or representations, including any implied warranties of merchantability or fitness or any obligations on the part of Ridewell. Ridewell will not be liable for any business interruptions, loss of profits, personal injury, any costs of travel delays or for any other special, indirect, incidental or consequential losses, costs or damages.

Contact the Ridewell Warranty Dept. at 417.833.4565 - Ext. 135, for complete warranty information.