

# RSS-233 - 20K Truck

## Self-Steering Air-Ride Suspension

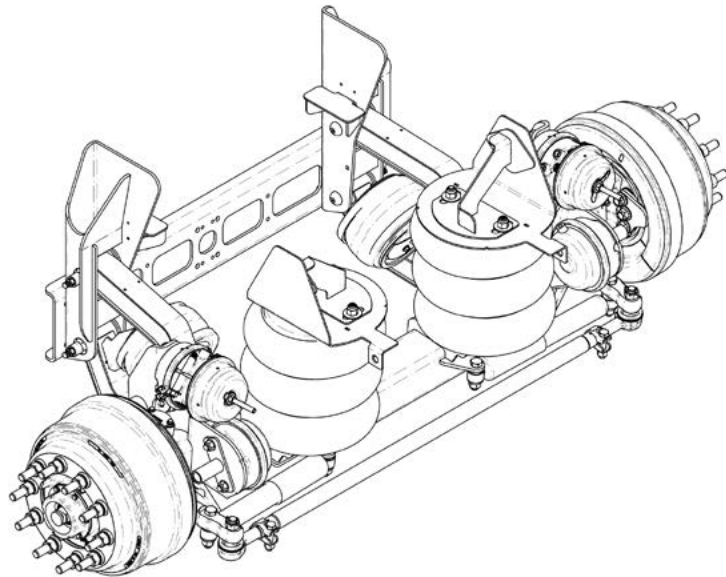

## Installation and Service Manual

### Suspension Identification

Prior to Installation	2
Suspension Mounting	3
Wheel Toe Setting/Drum Brake Fabricated Axle Assembly	4
Air Control Kit Components - Lift Axle	5

### Maintenance

Recommended Service Intervals	7
233-20K Truck Suspension – Bushing Replacement Kit/Procedure	8
20K Roll-Off Truck Drum Brake FAXL Components	10
Preplumbed Kit (Air Tank Integration)	11
Warranty	12





PART NO:

SUSP. NO:

SERIAL NO:

**GROSS AXLE WEIGHT RATING CERTIFICATION IS PER THE FINAL STAGE MANUFACTURER OR ALTERER.**

**THIS PRODUCT MAY BE COVERED UNDER ONE OR MORE PATENTS, ADDITIONAL PATENTS MAY BE PENDING.**

[www.ridewellcorp.com](http://www.ridewellcorp.com)

**(800) 641-4122**

**Suspension Identification Tag**

The **Part Number** (606- Installation/Assembly Number) when other components are factory installed.

The **Suspension Number** and **Serial Number** refer to the individual suspension and the date of manufacture.

Refer to the suspension number/part number/serial number when contacting Ridewell Customer Service.

**Self-Steering Option**

Self-steering suspensions are designed to steer only in the forward direction. The suspension must be raised off the ground or locked into a non-steering configuration during reverse travel to avoid damage.

Use caution when maneuvering in reverse with the steering lock engaged. The driver should maintain slow maneuvering speeds and avoid extreme turns.

1. Ridewell Suspensions strongly recommends the use of automated systems that raise/lock the lift-axle during reverse travel.
2. For manual operations, Ridewell recommends the installation of a visual/audible indicator to assist the driver.

**CAUTION** Failure to lift the suspension and-or engage the steering-lock during reverse travel can cause component damage and void the warranty.

**Notes and Cautions**

All work should be completed by a trained technician using the proper tools and safe work procedures.

Read through the entire Manual before performing any installation or maintenance procedures.

The ISM uses two service notes as important safety guidelines. The service notes are defined as:

“NOTE”: Provides additional instructions or procedures to complete tasks and ensure the suspension and other components function properly.

**CAUTION** Indicates a hazardous situation or unsafe practice that, if not avoided, could result in equipment damage and serious injury.

**Prior to Installation**

Refer to the engineering drawing to confirm dimensional requirements and the range of ride heights available. Installations can vary and procedures should be adapted for different vehicles as needed.

- The Gross Axle Weight Rating (GAWR) is determined by the system component with the lowest load rating. Please consult with tire, wheel, axle and brake manufacturers before installation to determine the GAWR.
- If vehicle chassis modifications are required, consult with the vehicle manufacturer to ensure that such changes are permitted.
- Welding or altering of suspension components is not permitted without the express written permission of Ridewell Suspensions.

**Installer Responsibilities**

The installer of the suspension has the sole responsibility for proper attachment of the suspension system to the vehicle chassis.

- The installer is responsible for locating the suspension system on the vehicle to provide the proper load distribution.
- The installer must verify that vehicle crossmembers are positioned to support the suspension at the installing location.
- The installer must verify there is sufficient clearance for proper functioning of the installed auxiliary suspension – air springs; brake chambers; steering components; axle (including axle to driveline clearance); and, tires and wheels.
- It is the installer’s responsibility to determine that axle spacing conforms to any applicable federal and local bridge laws.
- The installer must verify that air reservoir volume requirements are met after suspension installation. Consult the vehicle manufacturer or Federal Motor Vehicle Safety Standards (FMVSS) 121 for more information.



**Scan/double-click QR-Code or visit the online support page – [www.ridewellcorp.com](http://www.ridewellcorp.com)**

## Suspension Mounting

Refer to the engineering drawing for the suspension travel table; torque specifications; and, spacing and clearance requirements for mounting the suspension.

### Bolt-On Installation Procedure

Grade-8 bolts, flanged locknuts or locknuts with hardened washers are supplied by the installer.

The hanger locator flanges - when supplied - are installed to a preset ride height (Figure 1).

Loosen the crosschannel nuts on the 233-20K Roll-Off Truck Suspension before installation.

1. Measure the vehicle frame-width and hanger-to-hanger inside dimensions. Customer-supplied filler plates are required for the hangers and air spring mounting plates if vehicle frame-width is narrower than suspension preset frame width.
2. Place the suspension, with any hanger/air spring filler plates or hanger/air spring spacers, in the desired location for installation.  
NOTE: Frame crossmember must be located within six inches of leading or trailing edge of hanger.
3. Check the installation location for adequate clearance. The top of the hangers and air spring mounting plates must be parallel to the chassis frame to maintain the proper caster angle.
4. The frame hangers and air spring mounting plates should be perpendicular to the chassis frame and in alignment with each other. Clamp the hangers, the mounting plates, and any required spacer and filler plates firmly in place.
5. Refer to the engineering drawing for the hanger/air spring mounting plate bolt-hole locations.  
**CAUTION** If the recommended bolt-hole locations are not available, locate and drill the bolt-holes as far apart as possible to provide the most support for the assembled suspension.  
Check to make sure that wires, hoses or other components located within the frame rail are not affected by drilling.
6. Center-punch and drill six bolt-holes in each frame hanger. Bolt each hanger to the frame with 5/8-inch Grade 8 bolts and locknuts.
7. Center-punch and drill two bolt-holes in each air spring mounting bracket. Bolt each air spring mounting bracket to the frame with two 5/8-inch Grade 8 bolts and locknuts.
8. Install/connect air control kit (ACK) to suspension (Page 5). Check entire air system for leaks.

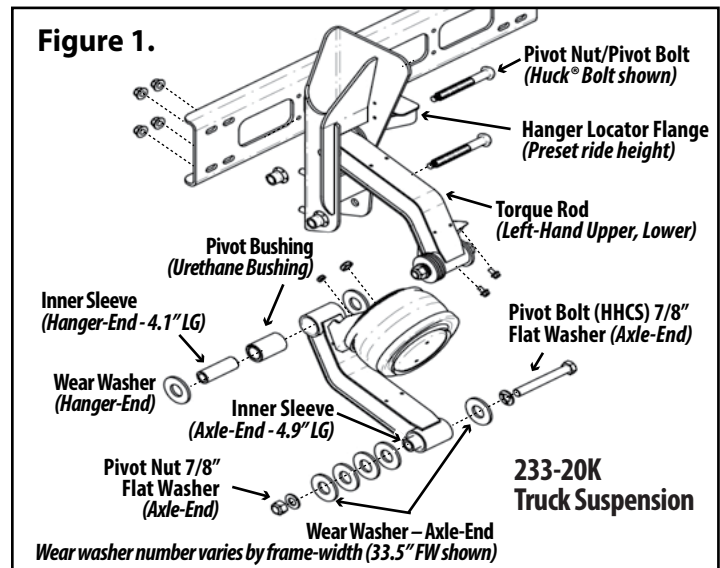

9. Perform final assembly and inspection.

**CAUTION** Reduce pressure to load springs below 10 PSI when lowering an auxiliary axle on an unloaded vehicle. Failure to reduce air pressure could cause drive axles to rise and vehicle could roll in an unsafe manner.

### Final Assembly and Inspection

1. Verify components are torqued to specs (Page 8).
2. Install wheels and tires.
3. Check that tires are inflated to recommended pressure. Check wheel hubs for proper level of lubricant recommended by the manufacturer.
4. Lift the axle to the raised position. Check the air system tubing and connections for leaks.
5. Check that wheels can rotate freely and that brakes and slack adjusters are properly adjusted.
6. Raise and lower suspension assembly (wheels and tires installed) through entire range of travel to verify sufficient clearances for air springs, brake chambers and other components are provided.
7. Check the vehicle's reverse travel options:
  - 7.1 Check steer-lock operation.
  - 7.2 Check automated system to verify suspension raises/locks wheels during reverse travel.**CAUTION** Failure to check reverse-travel can result in component damage and void the warranty.  
**CAUTION** Do not lower auxiliary axle while vehicle is moving above 10 mph in forward- or reverse- travel.

Verify wheel toe-in setting is between 1/32" and 3/32". Adjust if necessary (Page 4).

**CAUTION** Failure to torque bolts/nuts of suspension components to specifications can result in failure of the suspension and void the warranty.

## Wheel Toe Setting

Wheel toe is the relationship of the distance between the front of the tires and the distance between the rear of the tires on the same axle. When the front distance is less than the rear distance, the wheels are in a “toe-in” (positive toe) condition.

The correct setting for the RSS-233 suspension should be toe-in between 1/32” and 3/32”.

### Check Wheel Toe Setting

1. Deflate the air springs.
2. Lift the axle enough for tires to rotate freely. Support with jack stands to ensure axle is level.
3. Position tires to point straight ahead. Spin each tire. Use a piece of chalk to mark a line on the center tread all the way around the tire.
4. Use the centerline mark to measure the distance from the front of the tire to the frame. Measure the distance from the back of the tire to the frame.
5. Subtract the front of the tire distance from the rear distance to obtain the wheel toe setting.

### Adjust Wheel Toe

1. Loosen clamps on both ends of the tie rod. Twist the tie rod forward/backward to move the front of the tire towards or away from the frame.
2. Continue rotating the tie rod until the proper toe-in setting is achieved.
3. Torque tie-rod clamps to 60-80 ft-lb (81-108 N-m).

### Regulate load with air spring pressure

The load capacity of the auxiliary axle is adjusted by increasing or decreasing the pressure to the air springs. By applying more air, the lift axle takes on a greater percentage of the load’s weight. The load capacity is decreased as the air pressure decreases.

Accurate readings of the load capacity can be obtained by parking a loaded vehicle over a calibrated scale and lowering the axle onto the scale. The air pressure to the air springs is manually adjusted up or down to obtain the axle load weight at various air pressures.

**CAUTION** Do not exceed the rated load capacity of the suspension system or other components. Exceeding the capacity can cause component failure and void the warranty.

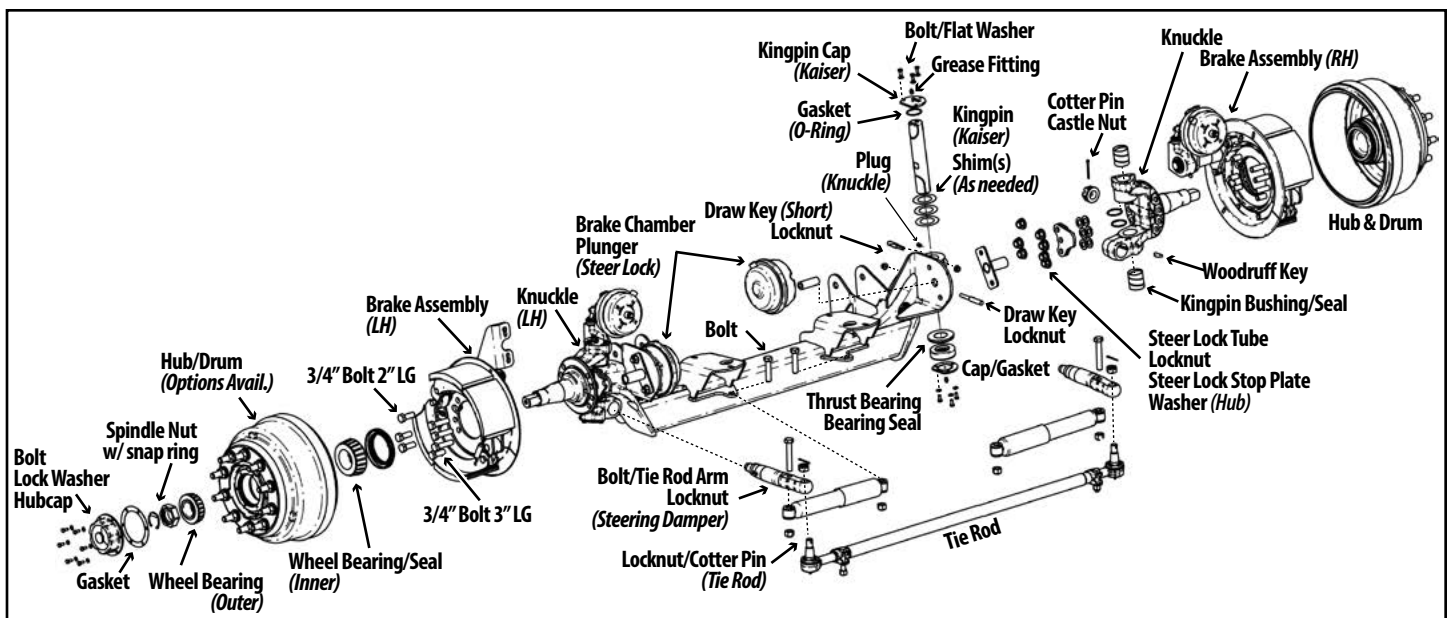

Figure 2.

**Drum Brake Fabricated Axle Assembly (Optional Steer Lock; Kaiser Kingpin shown)**  
(Reference only. Drum brake fabricated axle can be configured with a Standard Kingpin.)

## Air Control Kit components - Lift Axle

The air control kit (ACK) consists of a pressure regulator with a gauge connected to an air valve controlled by a manual knob or an electric switch. The operator uses the ACK to control the pressure to the air springs to support different loads.

**⚠️ CAUTION** The installer is responsible for making sure that air system requirements comply with the appropriate Federal Motor Vehicle Safety Standards.

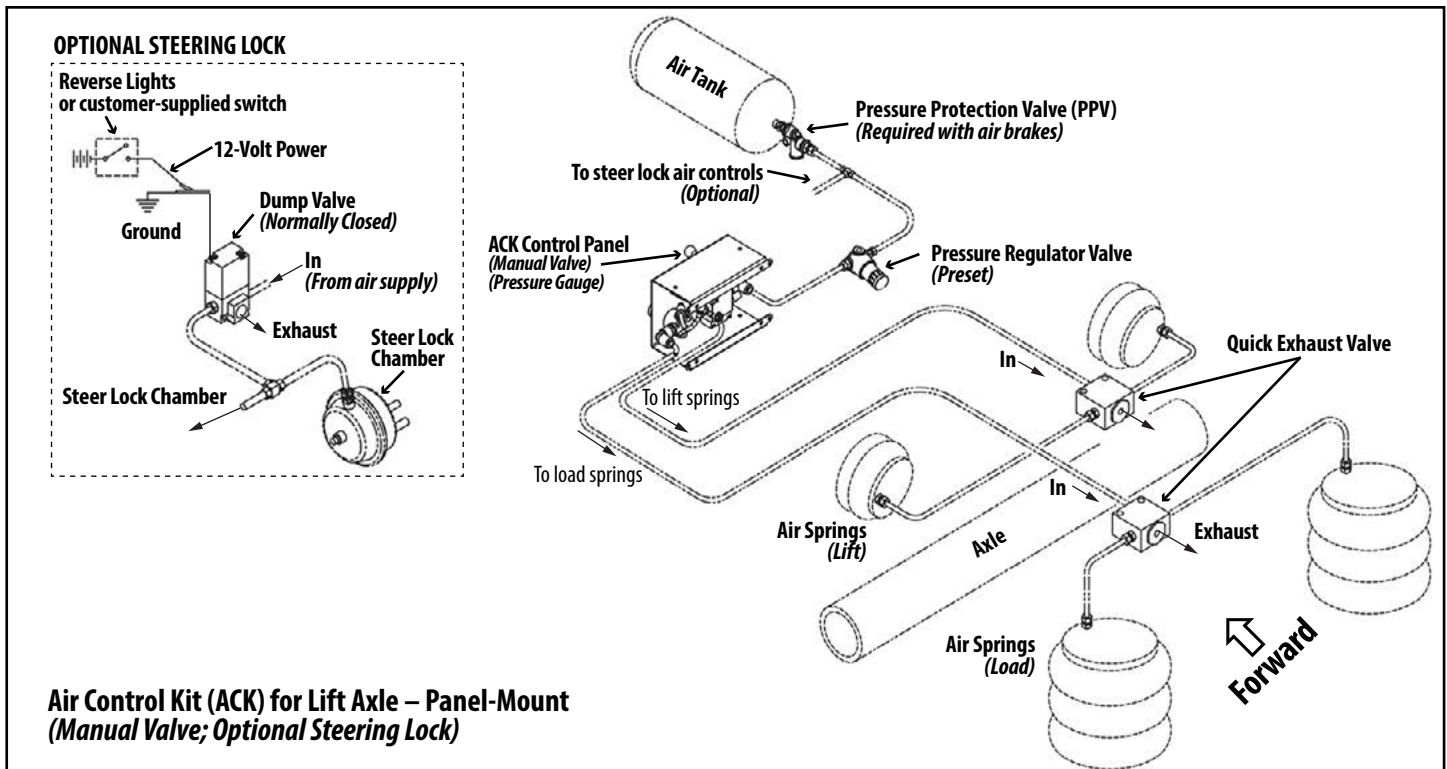

## ACK Installation – Troubleshooting

Problem	Possible Cause	Solution
<b>Air springs fill but do not exhaust.</b>	<ul style="list-style-type: none"> <li>– Obstructed air line.</li> <li>– Faulty controls wiring.</li> <li>– Manual override pushed in.</li> </ul>	<ul style="list-style-type: none"> <li>– Check for pinched/blocked lines.</li> <li>– Check wiring with voltmeter and correct wiring/installation.</li> <li>– Release manual override.</li> </ul>
<b>Air system leaks down after a short period of time.</b>	<ul style="list-style-type: none"> <li>– Leak in air system beyond accepted standards. NOTE: Some valves will leak at an acceptable rate.</li> </ul>	<ul style="list-style-type: none"> <li>– Pressurize system and spray soapy water solution onto the tubing, valves and fittings. Check for bubbles (leaks).</li> <li>– Check that tubing cuts are straight and smooth. Re-cut and reassemble fitting joints, if necessary.</li> </ul>
<b>Auxiliary unit will not stay up</b>	<ul style="list-style-type: none"> <li>– Loose air fitting connection/Damaged air lines.</li> <li>– Air lines to lift and load air springs are reversed.</li> <li>– Damaged or worn air springs.</li> </ul>	<ul style="list-style-type: none"> <li>– Check and retighten fittings. Repair or replace component, as necessary.</li> <li>– Check installation. Air line from regulator goes to (load) air springs.</li> <li>– Replace air spring if worn or damaged.</li> </ul>
<b>Auxiliary unit not achieving correct lift</b>	<ul style="list-style-type: none"> <li>– Air lines to lift and load air springs are reversed.</li> <li>– Lift air springs do not have proper air pressure.</li> <li>– Interference with driveline/other chassis components.</li> <li>– Air control system not installed correctly.</li> </ul>	<ul style="list-style-type: none"> <li>– Check installation. Air line from regulator goes to (load) air springs.</li> <li>– Check for loose fittings or worn/damaged lines. Verify air tank pressure with gauge.</li> <li>– Visually inspect auxiliary unit operation for proper clearance. Retighten any loose fasteners.</li> <li>– Check air control kit installation; refer to OEM installation procedures.</li> </ul>

## ACK-Lift Axle Control Module with Lift-In-Reverse

### Lift-In-Reverse-Wiring Diagram

Note: Relay is required only for lift-in-reverse operation

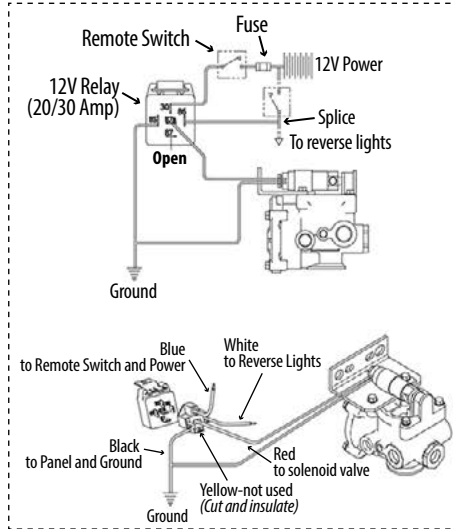

Pressure Protection Valve (PPV)  
(Required with air brakes)

ACK Control Panel  
(Pressure Gauge)  
(Pressure Regulator)  
(No valve)

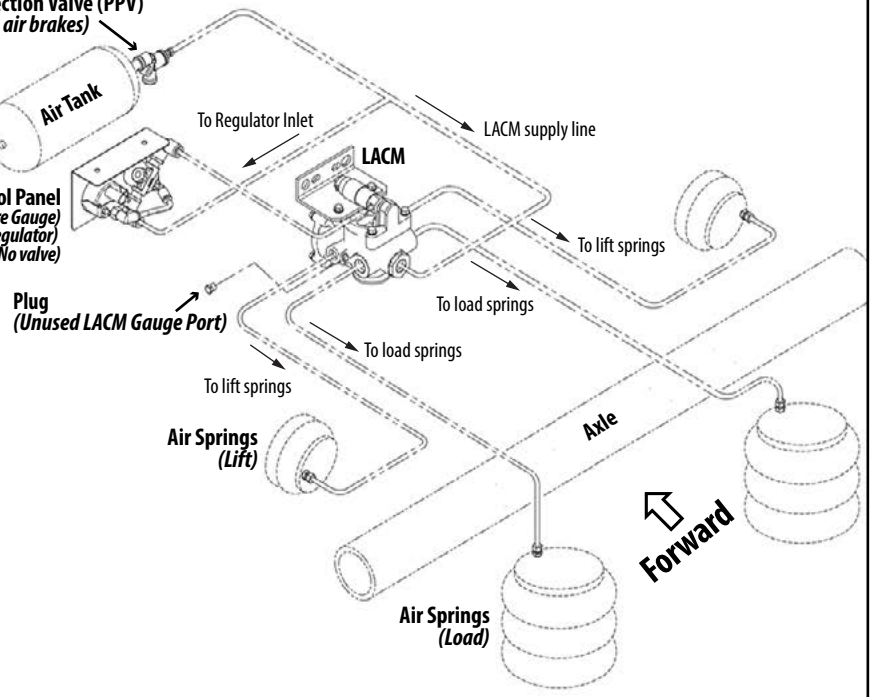
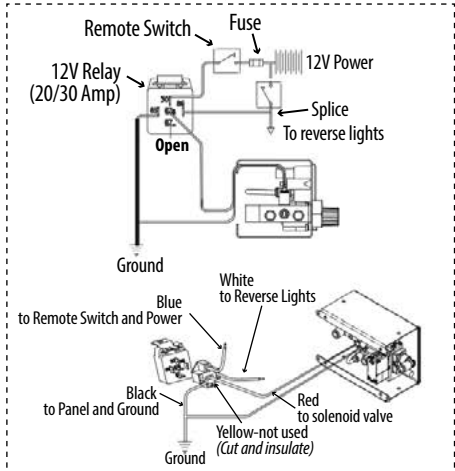

Figure 3. Example - Air Control Kit using Lift Axle Control Module (LACM) with Lift-In-Reverse system

## Panel-Mount ACK for Lift Axle w/ Lift-In-Reverse (Electric Valve; Optional Steering Lock)

### Lift-In-Reverse-Wiring Diagram

Note: Relay is required only for lift-in-reverse operation



Pressure Protection Valve (PPV)  
(Required with air brakes)

ACK Control Panel  
(Electric Valve)  
(Pressure Gauge)

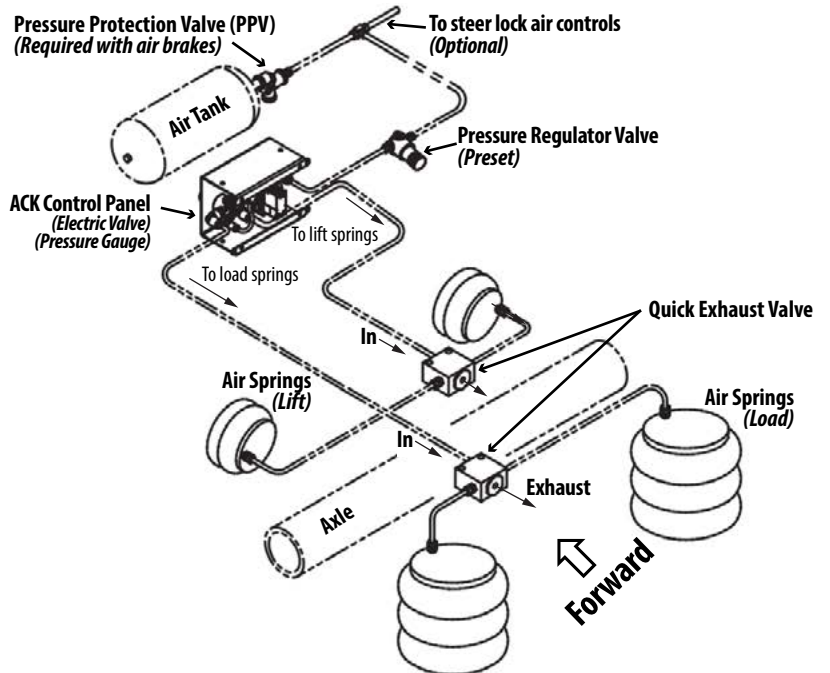

Figure 4. Example - Air Control Kit using Quick Exhaust Valves (QE Valve) with Lift-In-Reverse system

**Recommended Service Intervals**

Ridewell Suspensions recommends these minimum service intervals for standard duty, on-highway usage suspension applications.

More frequent service intervals are recommended for off-highway/heavier duty applications.

**Daily/Pre-Trip Inspections**

- \_\_\_ Visually inspect suspension structure for signs of damage or excessive wear.
- \_\_\_ Check for loose or missing bolts/nuts. Check for irregular movement in suspension system components.
- \_\_\_ Check tires for proper inflation, road damage or excessive wear.
- \_\_\_ Check wheel-ends for obvious signs of lubricant leakage. Check for missing components.
- \_\_\_ Make sure air controls are operating properly. Drain all moisture from air reservoirs.

**First 6,000 miles of use**

- \_\_\_ Torque all bolts/nuts to specifications (Page 8).

**Every 12,000 miles of use**

- \_\_\_ Lubricate Brake Cam and Slack Adjuster.
- \_\_\_ Grease kingpin thrust bearings. Apply grease in upper and lower grease fittings until new grease is visible at the purge location. Wipe the excess grease from purge areas and grease fittings.
- \_\_\_ Inspect steering damper for damage/wear.
- \_\_\_ Inspect air springs for damage/excessive wear. Torque bolts/nuts to specifications (Page 8).
- \_\_\_ Check air system for leaks.

**First 50,000 miles of use**

- \_\_\_ Check wheel-end/knuckle for excessive play.
- \_\_\_ Inspect tie-rod and tie-rod ends for excessive damage/wear. Lubricate tie-rod ends. Verify tie-rod boot is in place and completely over the end of tie-rod. Replace entire tie-rod end if boot is damaged.
- \_\_\_ Check pivot bushings for wear.
- \_\_\_ Torque all suspension system component bolts/nuts to specifications (Page 8).
- \_\_\_ Check (reverse) steer lock operation (if equipped).
- \_\_\_ Verify operation of manual/automatic lift-in-reverse control system (if equipped).

**Annual/100,000 Miles Inspection**

- \_\_\_ Inspect pivot connections for worn bushings/wear washers. Replace if necessary. Torque pivot hardware to specifications (Page 8).
- \_\_\_ Check lubrication level in wheel-ends. Refill/Replace lubricant as needed. *(TMC RP 631-Wheel End Lubrication Procedure)*
- \_\_\_ Check frame hanger and air spring mounting plate connections to frame.
- \_\_\_ Check air system for leaks.
- \_\_\_ Test air tank pressure protection valve (PPV) if equipped.
- \_\_\_ Check brakes/brake chambers for damage/function.

**⚠CAUTION** Failure to exhaust all pressure from the air system before vehicle work can cause serious injury.

**⚠CAUTION** Failure to torque suspension components to specifications can result in suspension failure and void the warranty.

**Refer to these Technology & Maintenance Council (TMC) Recommended Procedures for additional information:**

RP 609	Self-Adjusting/Manual Brake Adjuster Removal, Installation and Maintenance
RP 618	Wheel Bearing Adjustment Procedure
RP 619	Air System Inspection Procedure
RP 622	Wheel Seal and Bearing Maintenance
RP 631	Wheel End Lubrication Procedures
RP 643	Air Ride Suspension Maintenance Guidelines
RP 645	Tie-Rod End Inspection/Maintenance
RP 651	Steer Axle Maintenance Guidelines

**Available Wheel-End Lubricants**

Lubricant Type	Part No.	Item Description
Mineral Oil	380008G	(CITGO) MP GearOil 631310001-80W-90
Synthetic Oil	1980006	(SHELL) Synthetic API GI-5 75W-90 Oil
Synthetic Hard-Pack Grease	1980007	(CITGO) Synthetic Grease

## 233-20K TRUCK SUSPENSION – BUSHING REPLACEMENT KIT

Part Number (Component)	Item Description	Size	Torque Values	
			foot-pound	Newton-meter
<b>6040145 - Bushing Kit</b>	Traditional Hardware (HHCS/Locknut)	7/8"-14NF	500 ft-lb	678 N-m
<b>6040142 - Bushing Kit</b>	(No Pivot Hardware)			
<b>Fasteners</b>	Locknut - (Air Spring; Upper)	3/4"-16NF	50 ft-lb	68 N-m
	Locknut - (Air Spring; Lower)	1/2"-13NC	25 ft-lb	34 N-m
	Locknut - (Lift Spring; Outer)	1/2"-20NF	25 ft-lb	34 N-m
	Locknut - (Lift Spring; Inner)	3/4"-16NF	50 ft-lb	68 N-m
	Flanged Lock Screw - (Lift Spring)	3/8"-16NC	25 ft-lb	35 N-m
	Locknut - (Tie Rod/Steering Damper)	3/4"-10NC	160 ft-lb	217 N-m
	Locknut - (Crosschannel)	5/8"-11NC	160 ft-lb	217 N-m

Torque values reflect a lubricated thread condition (Nuts are pre-lubed). Do not overtorque.

**CAUTION** Suspension is shipped with minimal torque applied to fasteners. All fasteners must be re-torqued after first 6,000 miles of operation. Failure to install and maintain fasteners at torque specifications could result in suspension failure and void the warranty.

### Vehicle Preparation

Park the vehicle on a level surface. Chock wheels to keep vehicle from moving.

Exhaust all air from the air system. Disassemble suspension, if necessary, to reach pivot connections.

**CAUTION** Failure to properly chock wheels and completely exhaust the air system could allow vehicle movement that could result in serious injury.

### Bushing Replacement Procedure

- Count the number of wear washers on each side of the bushing on the Axle-End Torque Rod Assembly. The wear washer number varies according to the frame-width set by the hangers (Figure 5).
- Cut/grind away Huck® Collars at the hanger-end pivot connection. Take pivot connection apart. Discard pivot hardware. Discard wear washers.
- Remove bushing assembly from torque rod and discard. Clean rod eye of debris/corrosion.
- Remove traditional hardware at the axle-end pivot connection. Take pivot connection apart. Discard pivot hardware. Discard wear washers.
- Remove bushing assembly from torque rod and discard. Clean rod eye of debris/corrosion.
- Apply Energy Suspensions® Formula 5 Prelube to the bore (inside) of replacement bushings. NOTE: Do not substitute - special urethane bushing lubricant included with bushing kit.
- Install new bushing into the eye of the torque rod. NOTE: Mallet /press needed to install bushing.

*continued on next page*

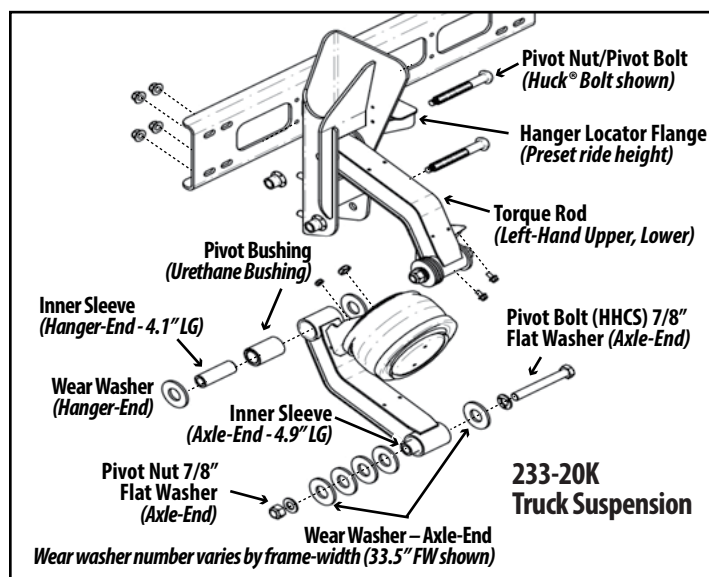

**Figure 5.**

**Bushing replacement kit includes wear washers and traditional hardware components to replace eight pivot connections.**

**Replace Huck™ fasteners at the hanger-end pivot connection with traditional hardware.**

**Refer to the engineering drawing to install the correct number of wear washers on the axle-end pivot connection of left-hand and right-hand torque rod.**



## 233 20K Truck/Roll-Off Truck – Bushing Replacement (continued)

8. Hanger-End-Wear Washer Installation –  
(Bushing Sleeve - 4.1")  
Press inner sleeve into the installed bushing. Center sleeve so that both ends extend slightly past the sides of the bushing. Assemble the pivot connection with one wear washer on each side of bushing (Figure 6).
- Inner sleeve must be flush with or extend slightly past the outside of wear washers on both sides.
9. Axle-End-Wear Washer Installation –  
(Bushing Sleeve - 4.8")  
Press the inner sleeve into the installed bushing. Position inner sleeve so that one end extends further past the bushing than the other end.
- Assemble pivot connection with the appropriate number of wear washers installed on both sides of the inner sleeve (Figure 6).
- Inner sleeve must be flush with or slightly past the outside of the wear washers on both sides.
10. Torque pivot nut to specifications  
(500 ft-lb - 678 N-m).
11. Reassemble suspension, if necessary.  
Torque components to specifications.
12. Verify wheel toe-in setting between 1/32" and 3/32." Adjust if necessary (Page 4).

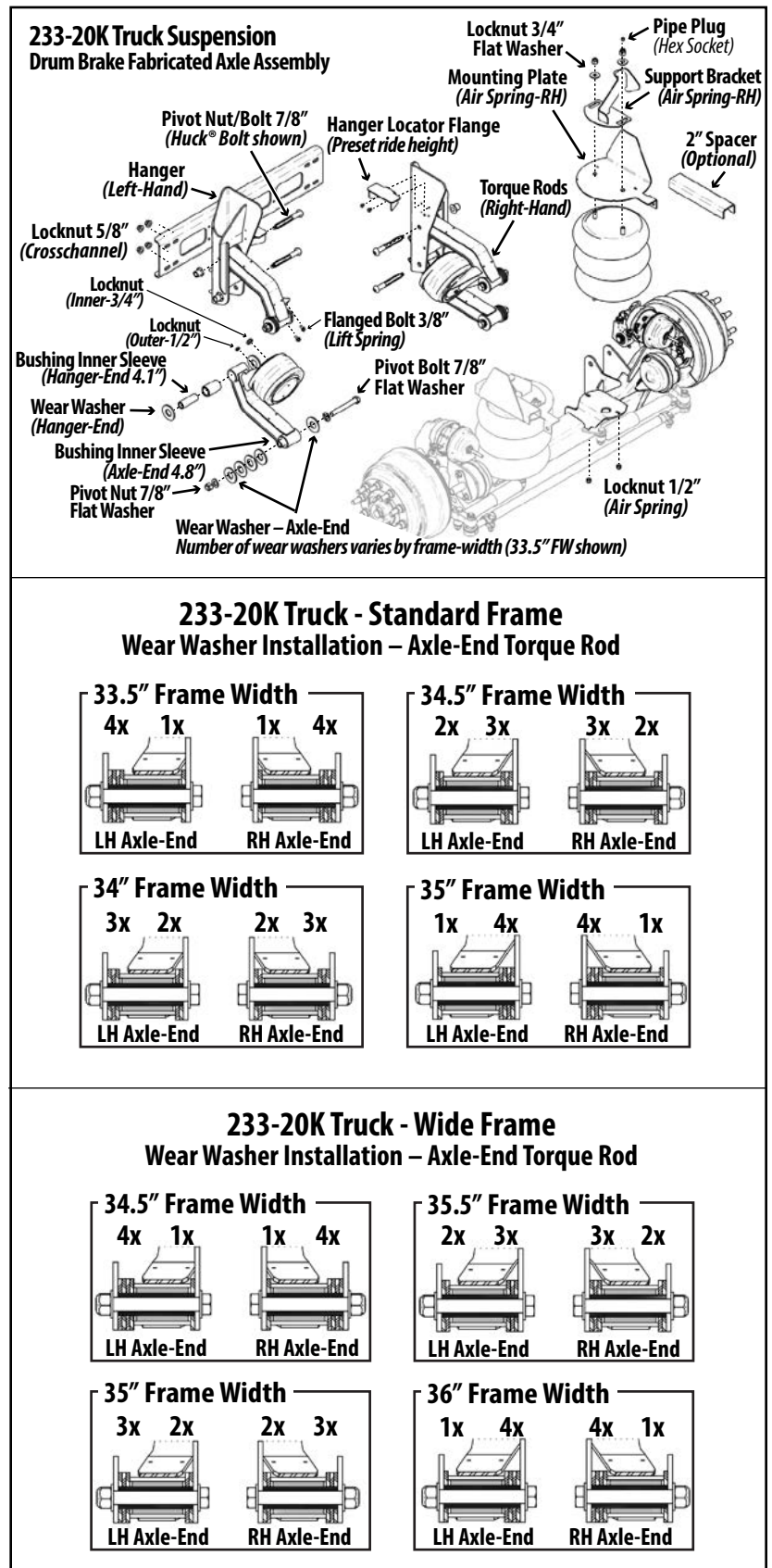

**Figure 6.**  
Refer to the engineering drawing for the number of wear washers installed at LH- and RH- axle-end pivot connection.

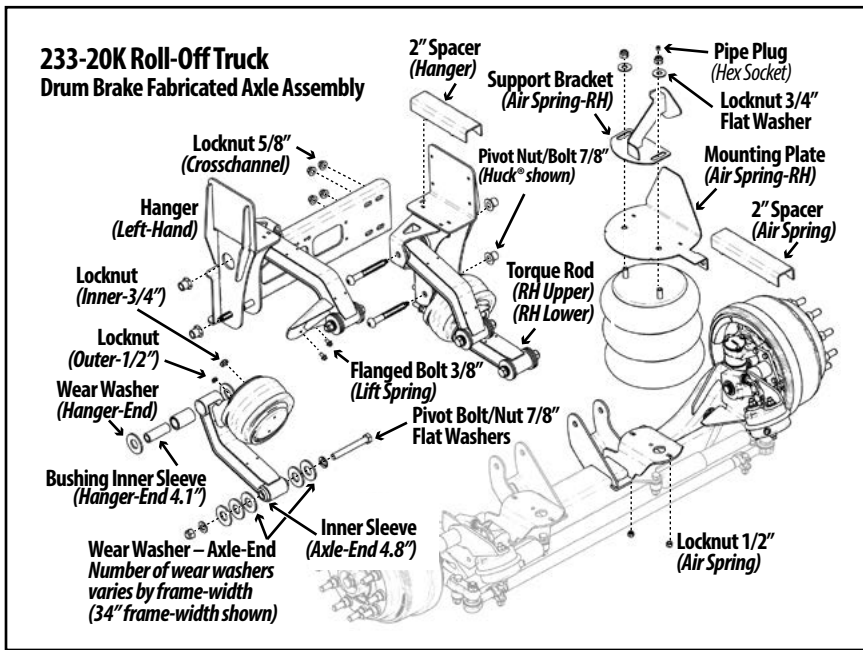

**Figure 7.**  
**20K Roll-Off Truck**  
**Suspension Components**  
**Drum Brake Fabricated Axle (FAXL)**  
 Refer to the engineering drawing for the individual component part number.

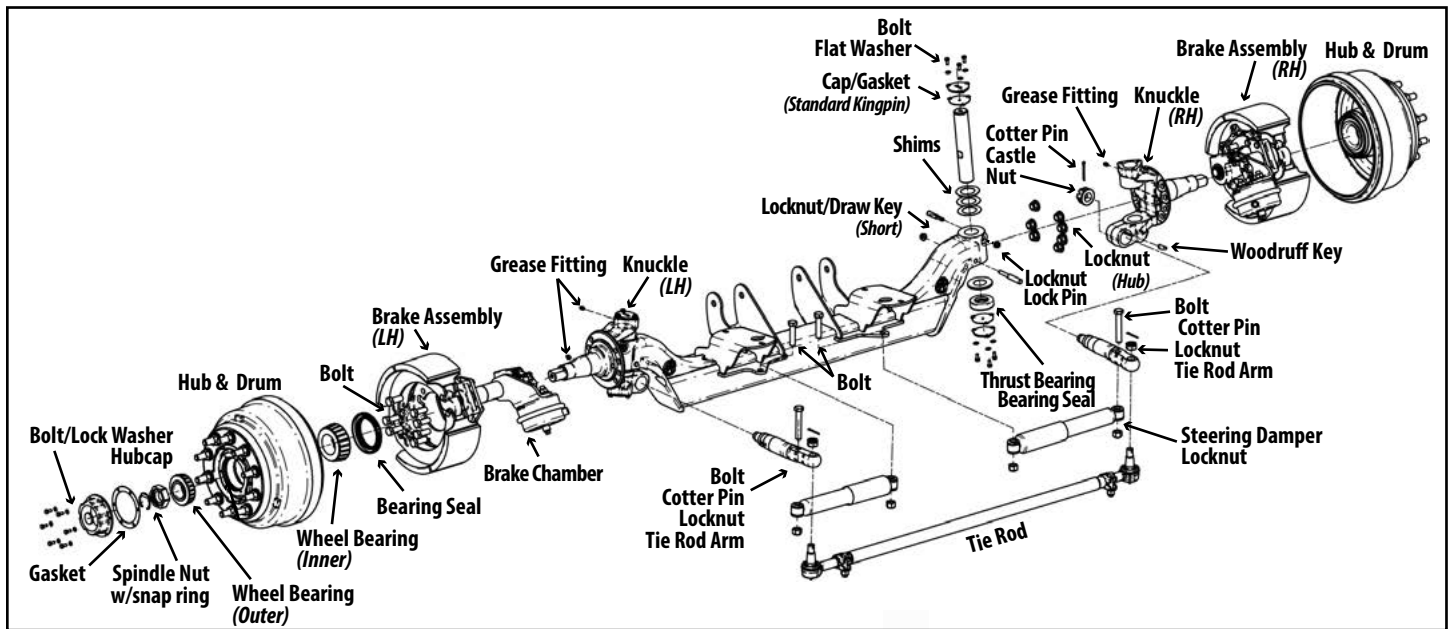

**Figure 8.**  
**Roll-Off Truck - Drum Brake Fabricated Axle Assembly (Standard Kingpin).**  
 (Reference only. Drum brake FAXL for 20K Roll-Off Truck Suspension can be configured with a Kaiser Kingpin)

## Preplumbed Kit (Air Tank Integration)

(Part No.) Kit Components	(P/N) Includes Factory Installation	Item Description	Air Tank—2200-Cu In	Pressure Protection Valve (PPV)	Brake Relay Valve	Lift Axle Control Module (LACM)	Quick Exhaust Valve (QE)
1200242	1200244	<b>LACM Kit – Suspension w/ Drum Brakes</b> <i>Assembly – valves; fittings and air lines from air springs to tank.</i>	1230129	1230060	1230081	1230195	
1200246	1200247	<b>Air Tank; Brake Relay Valve; Fittings</b> <i>Assembly – Brake Relay Valve and fittings (No air lines).</i>					
1200279	1200280	<b>LACM Kit – Suspension w/ Disc Brakes</b> <i>Assembly – valves; fittings and air lines from air springs to tank.</i>	1230129	1230060	1230081	1230195	
1200283	1200284	<b>Quick Exhaust Valve Kit—Suspension w/ Disc Brakes</b> <i>Assembly – valves; fittings and air lines from air springs to tank.</i>					

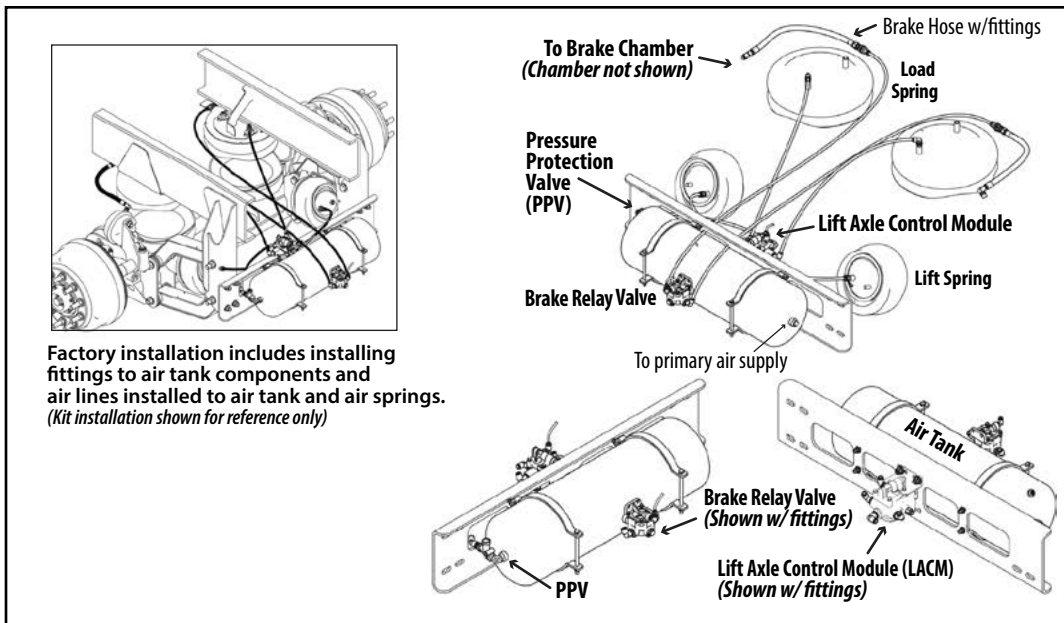

**Figure 9.**  
Preplumbed example –  
1200242 Integration Kit  
20K Truck w/ Drum Brake

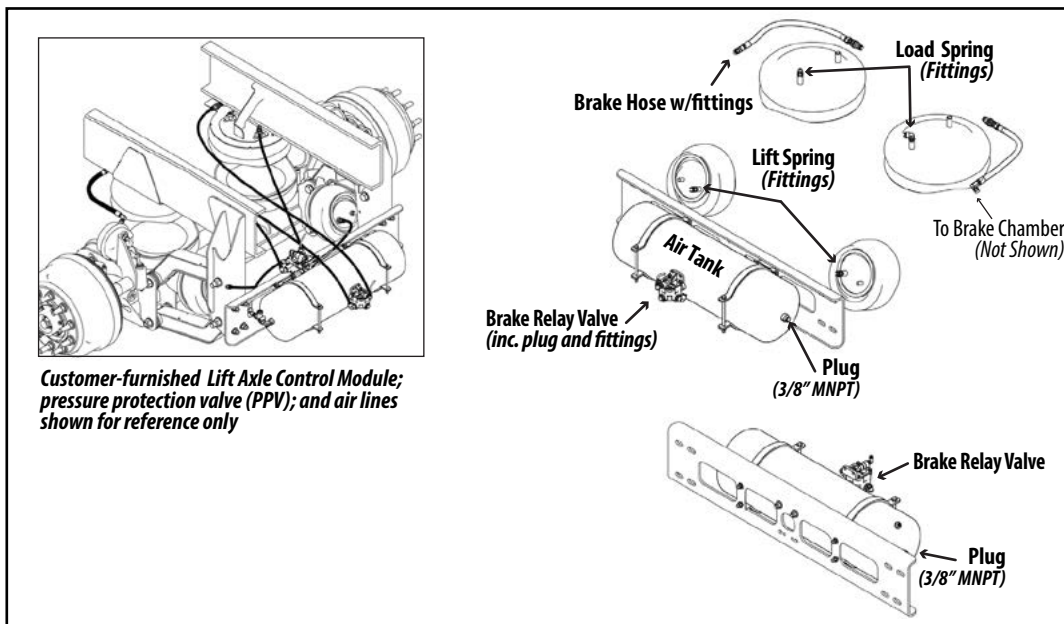

**Figure 10.**  
Preplumbed example –  
1200246 Integration Kit:  
Air Tank; Brake Relay Valve  
and Fittings only  
(No LACM; No PPV; No air lines)

**Terms and coverage in this warranty apply only to the United States and Canada.**

Ridewell Suspensions warrants the suspension systems manufactured by it to be free of defects in material and workmanship. Warranty coverage applies only to suspensions that have been properly installed, maintained and operated within the rated capacity and recommended application of the suspension. The responsibility for warranty coverage is limited to the repair/replacement of suspension parts. The liability for coverage of purchased components is limited to the original warranty coverage extended by the manufacturer of the purchased part.

All work under warranty must have prior written approval from the Ridewell warranty department. Ridewell has the sole discretion and authority to approve or deny a claim and authorize the repair or replacement of suspension parts. All parts must be held until the warranty claim is closed.

Parts that need to be returned for warranty evaluation will be issued a Returned Materials Authorization (RMA). Parts must be returned to Ridewell with the transportation charges prepaid. The transportation charges will be reimbursed if the warranty claim is approved.

This non-transferable warranty is in lieu of all other expressed or implied warranties or representations, including any implied warranties of merchantability or fitness or any obligations on the part of Ridewell. Ridewell will not be liable for any business interruptions, loss of profits, personal injury, any costs of travel delays or for any other special, indirect, incidental or consequential losses, costs or damages.

**Contact the Ridewell Warranty Dept. at 417.833.4565 - Ext. 135, for complete warranty information.**