

RSS-233 - 8K Truck Self-Steering – Auxiliary Axle Suspension

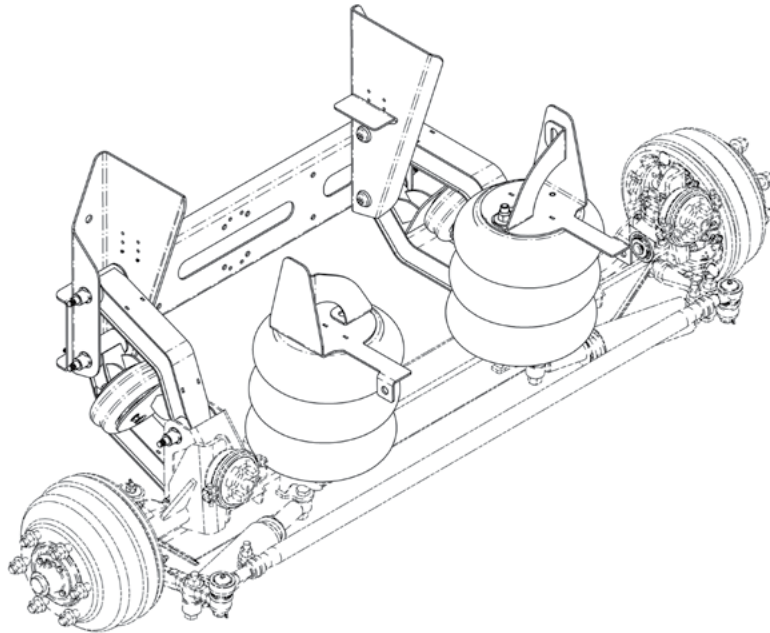

Installation and Service Manual

Suspension Identification	2
Prior to installation	3
Suspension Mounting	4
ACK Components - Lift Axle	6
Maintenance	
Recommended Service Intervals	8
Fabricated Axle Assembly (FAXL) Components	9
Bushing Replacement Kit	10
8K Truck Suspension Components (Drum Brake)	11
Warranty	12



SUSPENSION IDENTIFICATION



PART NO:

SUSP. NO:

SERIAL NO:

GROSS AXLE WEIGHT RATING CERTIFICATION IS PER THE FINAL STAGE MANUFACTURER OR ALTERER.

THIS PRODUCT MAY BE COVERED UNDER ONE OR MORE PATENTS, ADDITIONAL PATENTS MAY BE PENDING.

www.ridewellcorp.com

(800) 641-4122

Suspension Identification Tag

The Part Number is listed as 606- Installation/ Assembly Number when other components are factory installed with the suspension. The Suspension Number and Serial Number refer to the individual suspension model and the date of manufacture.

Refer to the suspension number/part number and serial number when contacting Ridewell for customer service, replacement parts and warranty information.

Notes and Cautions

Read through the entire Installation and Service Manual (ISM) before performing any procedures.

All work should be completed by a properly trained technician using the proper/special tools and safe work procedures.

The ISM uses two service notes to provide important safety guidelines for suspension system operation. The service notes are defined as:

“NOTE”: Provides additional instructions or procedures to complete tasks and make sure that the suspension functions properly.

CAUTION Indicates a hazardous situation or unsafe practice that, if not avoided, could result in equipment damage and serious injury.

Self-Steering Suspension Option

Steerable suspensions are designed to self-steer in the forward direction only.

The suspension must be raised off the ground or locked into a non-steering configuration during reverse travel to avoid damaging the suspension.

Use caution when maneuvering in reverse with the steering lock engaged. The driver should maintain slow maneuvering speeds and avoid extreme turns.

Ridewell Suspensions strongly recommends the use of automated systems that raise/lock the lift-axle during reverse travel.

For manual operations, Ridewell recommends the installation of a visual/audible indicator to assist the driver.

CAUTION Failure to lift the suspension and-or engage the steering-lock during reverse travel can cause component damage and void the warranty.



Scan/double-click the QR-Code or visit online support page at www.ridewellcorp.com

Prior to installation

The RSS-233-8K Truck Suspension System is a fully integrated, liftable auxiliary axle suspension configured with drum brakes and an optional steering lock.

Refer to the suspension model engineering drawing for dimensional requirements; available ride height; and, the suspension system operating parameters.

Installations can vary. Procedures should be adapted for different vehicles, as needed.

- The Gross Axle Weight Rating (GAWR) is determined by the system component with the lowest load rating. Please consult with the tire, wheel, axle and brake manufacturers before installation to determine the GAWR.
- If vehicle chassis modifications are required, consult with the vehicle manufacturer to ensure that such changes are permitted.
- Welding or altering of suspension components is not permitted without the express written permission of Ridewell Suspensions.

Installer Responsibilities

- The installer of the suspension has the sole responsibility for proper attachment of the suspension system to the vehicle chassis.
- The installer is responsible for locating the suspension system on the vehicle to provide the proper load distribution.
- The installer must verify that vehicle crossmembers are positioned to support the suspension at the installing location.
- The installer must verify there is sufficient clearance for proper functioning of the installed auxiliary suspension – air springs; brake chambers; steering components; axle (including axle to drive-line clearance); and, tires and wheels.
- It is the installer's responsibility to determine that axle spacing conforms to any applicable federal and local bridge laws.
- The installer must verify that air reservoir volume requirements are met after suspension installation. Consult the vehicle manufacturer or Federal Motor Vehicle Safety Standards (FMVSS) 121 for more information.

Suspension Mounting

Refer to the engineering drawing for the suspension travel table; torque specifications; and, spacing and clearance requirements for mounting.

The 13K Truck Suspension hanger locator flange is factory installed at the preset ride height (Figure 1).

The ride height can be adjusted using a 1-inch or 2-inch air spring spacer kit (Page 11).

Bolt-On Installation Procedure

RSS-233 8K Truck Suspensions are shipped fully assembled. The suspension must be reassembled with proper torque applied if any component is removed/taken apart for installation.

Grade-8 bolts, flanged locknuts or locknuts with hardened washers are supplied by the installer.

1. Measure vehicle frame width and the hanger-to-hanger inside dimensions of the suspension.
NOTE: Customer-supplied filler plates are required for the hangers and air spring mounting plates if the vehicle frame width is narrower than the suspension pre-set frame width.
2. Place the suspension, with any hanger/air spring filler plates or hanger/air spring spacer, in the desired installation location.
NOTE: A crossmember must be located on the frame within six inches of the leading or trailing edge of the hanger.
3. Check the location to verify the adequate clearance for all suspension components. The top of the hangers and air spring mounting plates must be parallel to the chassis frame to maintain the proper caster angle.
4. The frame hangers and air spring mounting plates should be perpendicular to the chassis frame and in alignment with each other.
Clamp the hangers, the mounting plates, and any required spacer and filler plates firmly in place.
5. Refer to the engineering drawing for the recommended hanger/air spring mounting plate bolt-hole locations.
If the recommended bolt-hole locations are not available, locate and drill the bolt-holes as far apart as possible to provide the most support for the assembled suspension.

CAUTION Check to make sure that wires, hoses or other components located within the frame rail are not affected by drilling.

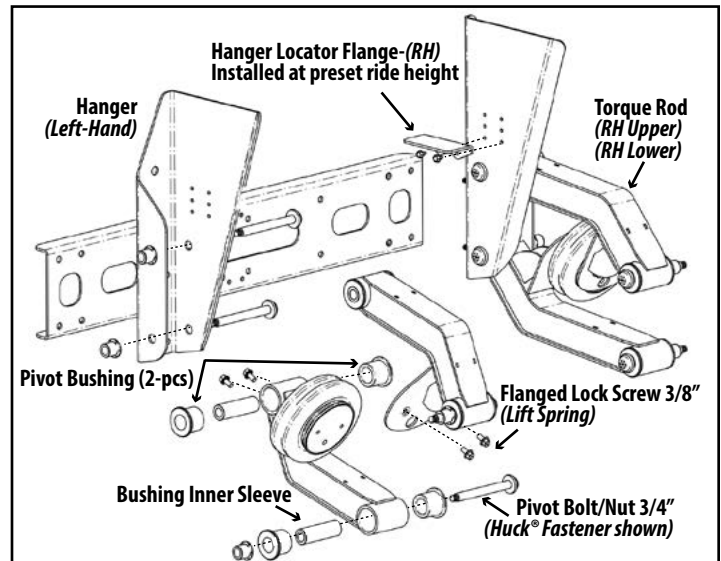

Figure 1.
Hanger locator flanges are factory installed to a preset ride height.

6. Center-punch and drill six bolt-holes in each hanger. Bolt each hanger to the frame with 5/8-inch Grade 8 bolts and locknuts.
7. Center-punch and drill two bolt-holes in each air spring mounting bracket. Bolt each air spring bracket to the frame with two 5/8-inch Grade 8 bolts and locknuts.
8. Install/connect air control kit (ACK) to the suspension (pg 6). Check air system after installation for leaks and proper operation of controls.
9. Perform final assembly and inspection and check the wheel toe setting (Page 5)

CAUTION Failure to torque bolts/nuts of suspension components to specifications can result in failure of the suspension and void the warranty.

Final Assembly and Inspection

1. Verify that all suspension component bolts/nuts are torqued to specifications.
2. Install wheels and tires.
CAUTION When lowering an auxiliary axle on an unloaded vehicle, pressure to the load air springs must be reduced to below 10 psi. Failure to reduce the air pressure could cause the vehicle's drive axles to rise from the ground and the vehicle could roll in an unsafe manner.
Do not lower the auxiliary axle while the vehicle is moving above 10 mph.

continued on next page

Regulate load with air spring pressure

The load capacity of the auxiliary axle is adjusted by increasing or decreasing the pressure to the air springs. By applying more air, the lift axle takes on a greater percentage of the load's weight. The load capacity is decreased as the air pressure decreases.

Accurate readings of the load capacity can be obtained by parking a loaded vehicle over a calibrated scale and lowering the axle onto the scale.

The air pressure to the air springs is manually adjusted up or down to obtain the axle load weight at various air pressures.

CAUTION Do not exceed the rated load capacity of the suspension system or components. Exceeding the capacity can cause component failure and void the warranty.

Final Assembly (continued from previous page)

3. Check that tires are inflated to recommended pressure. Check wheel hubs for proper level of lubricant recommended by the manufacturer.
4. Lift the axle to the raised position. Check the air system tubing and connections for leaks.
5. Check that wheels can rotate freely and that brakes and slack adjusters are properly adjusted.
6. Raise and lower the suspension assembly (wheels and tires installed) through the entire range of travel. Make sure that sufficient clearance for air springs, brake chambers and other components has been provided.
7. Check the vehicle's reverse travel options:
 - 7.1. Check steer-lock operation.
 - 7.2. Check automated system (if installed) to make sure that suspension raises/locks wheels during reverse travel.
8. Check wheel toe-in setting and adjust if necessary (between 1/32" and 3/32").

CAUTION Failure to check reverse travel operations can result in component damage and void the suspension warranty.

Wheel Toe Setting

Wheel toe is the relationship of the distance between the front of the tires and the distance between the rear of the tires on the same axle. When the front distance is less than the rear distance, the wheels are in a "toe-in" (positive toe) condition.

The correct setting for the RSS-233 suspension should be a positive toe-in between 1/32" and 3/32".

Check Wheel Toe Setting

1. Deflate the air springs.
2. Lift the axle enough for tires to rotate freely. Support with jack stands to ensure axle is level.
3. Position tires to point straight ahead. Spin each tire. Use a piece of chalk to mark a line on the center tread all the way around each tire.
4. Use a tape measure to measure the distance between the center mark at the front and the rear of the tires.
5. Subtract the distance measured at the front of the tires from the distance measured at the rear of the tires to obtain the wheel toe setting (between 1/32" and 3/32").

Adjust Wheel Toe

1. Loosen the clamps on both ends of the tie rod. Twist the tie rod forward/backward to move the front of the tires towards or away from each other (increase/decrease toe-in setting).
2. Continue rotating the tie rod until the proper toe-in setting is achieved.
3. Torque tie-rod clamps to 60-80 ft-lb (81-108 N-m).

Air Control Kit Components - Lift Axle

The air control kit (ACK) consists of a pressure regulator with a gauge connected to an air valve controlled by a manual knob or an electric switch. The operator uses the ACK to control the pressure to the air springs to support different loads.

CAUTION The installer is responsible for making sure that air system requirements comply with the appropriate Federal Motor Vehicle Safety Standards.

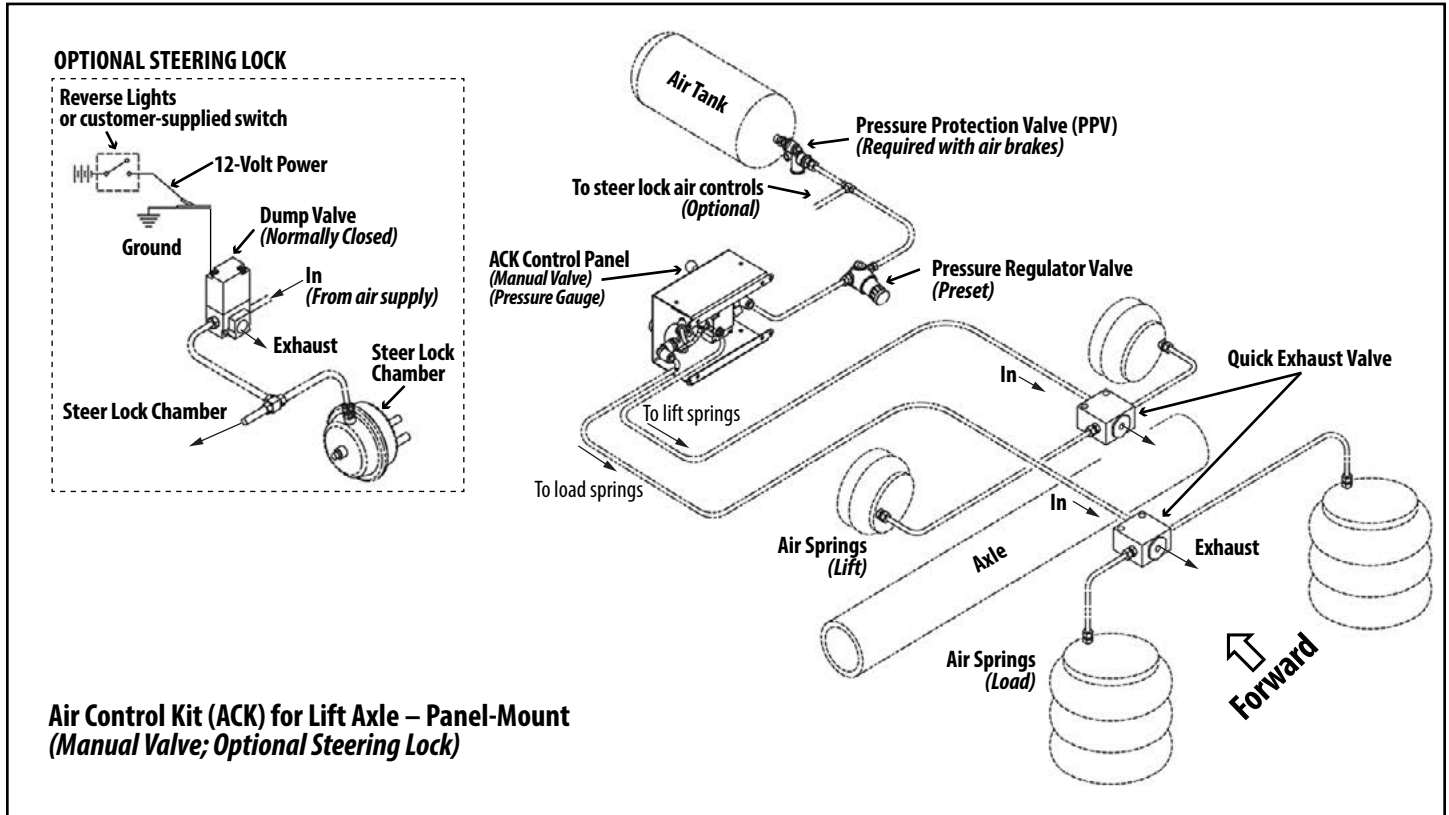

Problem	Possible Cause	Solution
Air springs fill but do not exhaust.	<ul style="list-style-type: none"> – Obstructed air line. – Faulty controls wiring. – Manual override pushed in. 	<ul style="list-style-type: none"> – Check for pinched/blocked lines. – Check wiring w/ voltmeter. Correct wiring/installation. – Release manual override.
Air system leaks down after a short period of time.	<ul style="list-style-type: none"> – Leak in air system beyond accepted standards. <p>NOTE: Some valves will leak at an acceptable rate.</p>	<ul style="list-style-type: none"> – Pressurize system. Spray soapy water solution on tubing, valves and fittings. Check for bubbles (leaks). – Check that tubing cuts are straight and smooth. Re-cut and reassemble fitting joints, if necessary.
Auxiliary unit will not stay up	<ul style="list-style-type: none"> – Loose air fitting connection/Damaged air lines. – Air lines to lift and load air springs are reversed. – Damaged or worn air springs. 	<ul style="list-style-type: none"> – Check and retighten fittings. Repair or replace component, as necessary. – Check installation. Air line from regulator goes to (load) air springs. – Replace air spring if worn or damaged.
Auxiliary unit not achieving correct lift	<ul style="list-style-type: none"> – Air lines to lift and load air springs are reversed. – Lift air springs do not have proper air pressure. – Interference with driveline/other chassis components. – Air control system not installed correctly. 	<ul style="list-style-type: none"> – Check installation. Air line from regulator goes to (load) air springs. – Check for loose fittings or worn/damaged lines. Verify air tank pressure with gauge. – Visually inspect auxiliary unit operation for proper clearance. Retighten any loose fasteners. – Check air control kit installation; refer to OEM installation procedures.

Panel-Mount ACK for Lift Axle w/ Lift-In-Reverse (Electric Valve; Optional Steering Lock)

Lift-In-Reverse-Wiring Diagram

Note: Relay is required only for lift-in-reverse operation

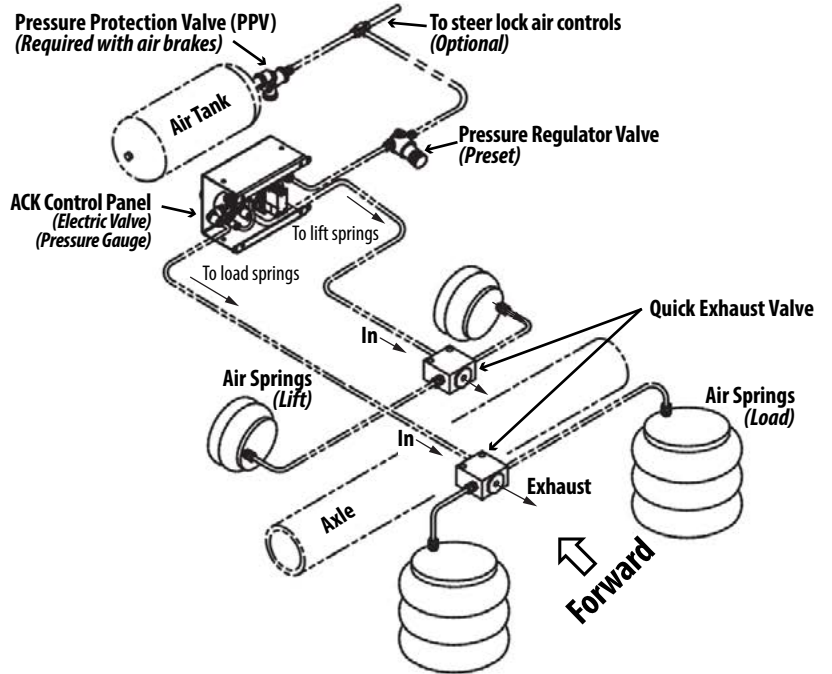
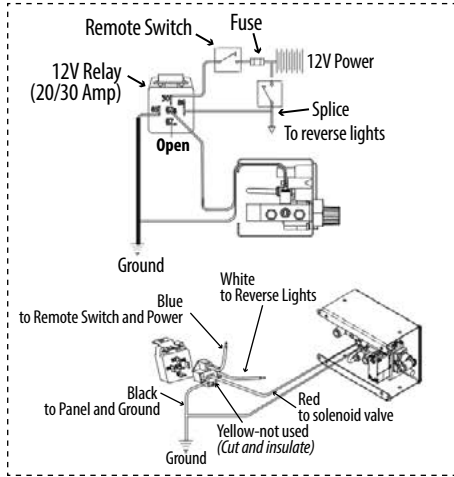

ACK-Lift Axle Control Module with Lift-In-Reverse

Lift-In-Reverse-Wiring Diagram

Note: Relay is required only for lift-in-reverse operation

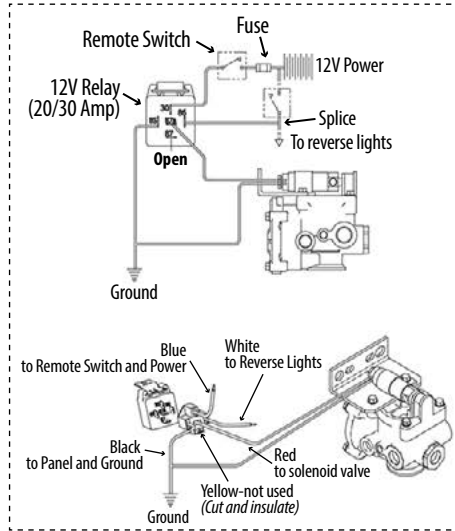

Pressure Protection Valve (PPV)
(Required with air brakes)

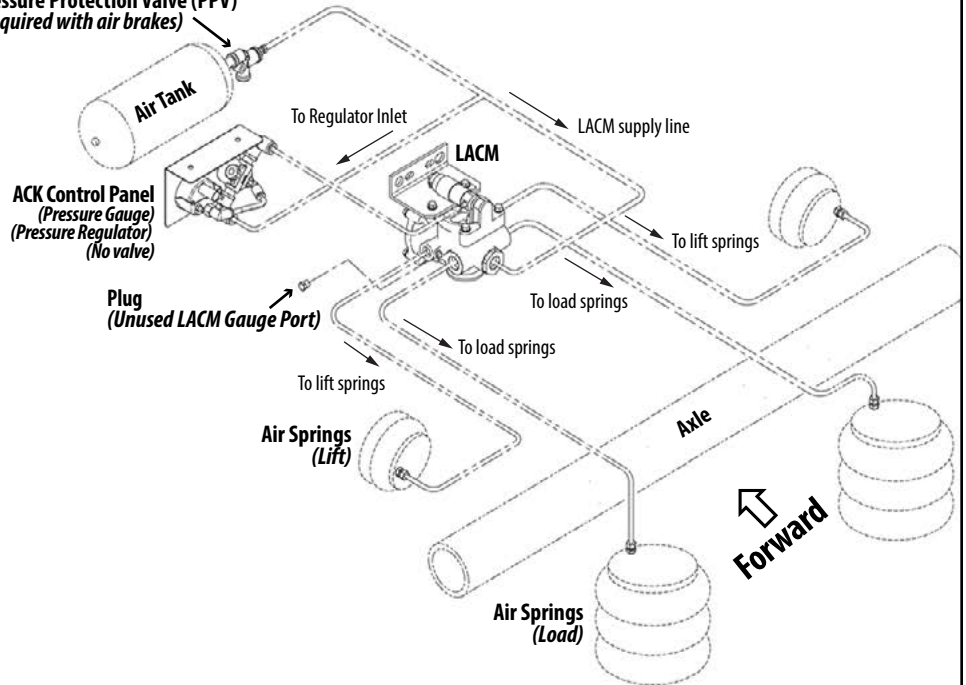

Recommended Service Intervals

Ridewell Suspensions recommends these minimum service intervals for standard duty, on-highway usage suspension applications.

More frequent service intervals are recommended for off-highway/heavier duty applications.

Daily/Pre-Trip Inspections

- ___ Visually inspect suspension structure for signs of damage or excessive wear.
- ___ Check for loose or missing bolts/nuts.
Check for irregular movement in suspension system components.
- ___ Check tires for proper inflation, road damage or excessive wear.
- ___ Check wheel-ends for obvious signs of lubricant leakage. Check for missing components.
- ___ Make sure air controls are operating properly.
Drain all moisture from air reservoirs.

First 6,000 miles of use

- ___ Torque all bolts/nuts to specifications (Page 10).

Every 12,000 miles of use

- ___ Lubricate Brake Cam and Slack Adjuster.
- ___ Grease kingpin thrust bearings. Apply grease in upper and lower grease fittings until new grease is visible at the purge location. Wipe the excess grease from purge areas and grease fittings.
- ___ Inspect steering damper for damage/wear.
- ___ Inspect air springs for damage/excessive wear.
Torque bolts/nuts to specifications (Page 10).
- ___ Check air system for leaks.

First 50,000 miles of use

- ___ Check wheel-end/knuckle for excessive play.
- ___ Inspect tie-rod and tie-rod ends for excessive damage/wear. Lubricate tie-rod ends.
Verify tie-rod boot is in place and completely over the end of tie-rod. Replace entire tie-rod end if boot is damaged.
- ___ Check pivot bushings for wear.
- ___ Torque all suspension system component bolts/nuts to specifications (Page 10).
- ___ Check (reverse) steer lock operation (if equipped).
- ___ Verify operation of manual/automatic lift-in-reverse control system (if equipped).

Annual/100,000 Miles Inspection

- ___ Inspect pivot connections for worn bushings/wear washers. Replace if necessary. Torque pivot hardware to specifications (Page 10).
 - ___ Check lubrication level in wheel-ends. Refill/Replace lubricant as needed.
(TMC RP 631-Wheel End Lubrication Procedure)
 - ___ Check frame hanger and air spring mounting plate connections to frame.
 - ___ Check air system for leaks.
 - ___ Test air tank pressure protection valve (PPV) if equipped.
 - ___ Check brakes/brake chambers for damage/function.
- ⚠CAUTION** Failure to exhaust all pressure from the air system before vehicle work can cause serious injury.
- ⚠CAUTION** Failure to torque suspension components to specifications can result in suspension failure and void the warranty.

Refer to these Technology & Maintenance Council (TMC) Recommended Procedures for additional information:

RP 609	Self-Adjusting/Manual Brake Adjuster Removal, Installation and Maintenance
RP 618	Wheel Bearing Adjustment Procedure
RP 619	Air System Inspection Procedure
RP 622	Wheel Seal and Bearing Maintenance
RP 631	Wheel End Lubrication Procedures
RP 643	Air Ride Suspension Maintenance Guidelines
RP 645	Tie-Rod End Inspection/Maintenance
RP 651	Steer Axle Maintenance Guidelines

Available Wheel-End Lubricants

Lubricant Type	Part No.	Item Description
Mineral Oil	380008G	(CITGO) MP GearOil 631310001-80W-90
Synthetic Oil	1980006	(SHELL) Synthetic API GI-5 75W-90 Oil
Synthetic Hard-Pack Grease	1980007	(CITGO) Synthetic Grease

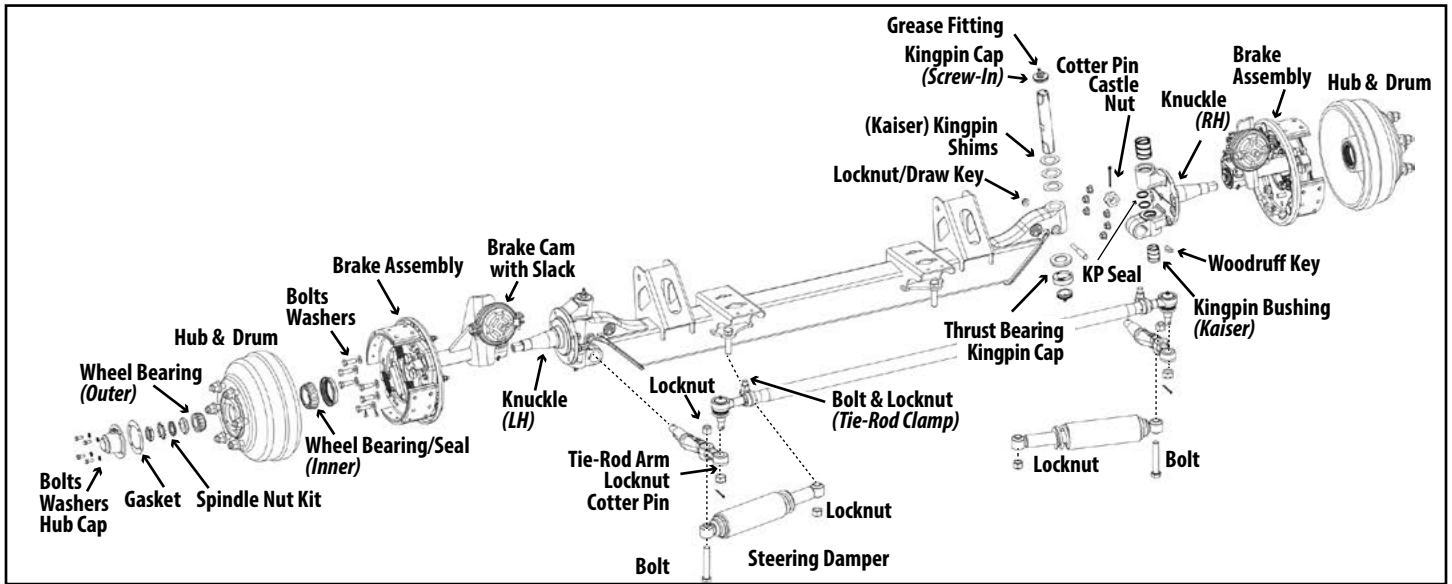

Figure 2.
Fabricated Axle Assembly (FAXL) – Steer Lock; Kaiser® Kingpin Components

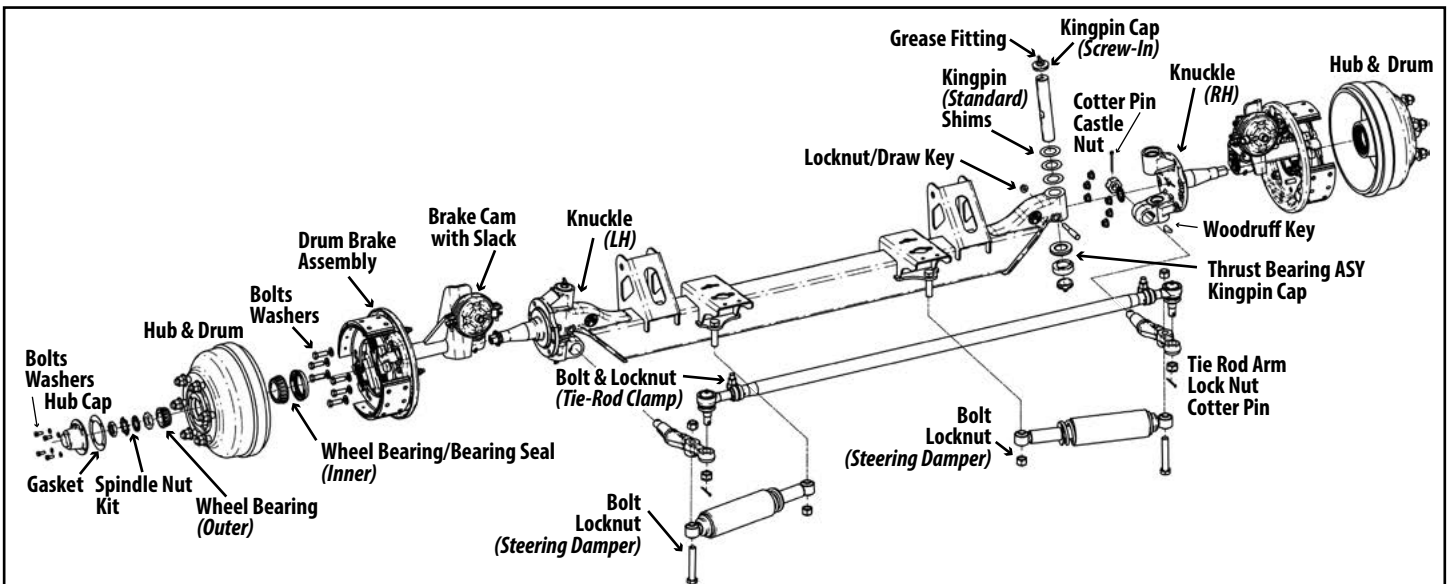

Figure 3.
Fabricated Axle Assembly (FAXL) – Steer Lock; Standard Kingpin Components

233-8K TRUCK SUSPENSION – BUSHING REPLACEMENT KIT

Part Number (Component)	Item Description	Size	Torque Values foot-pound Newton-meter	
6040134-Bushing Kit	Traditional Hardware (HHCS/Locknut)	3/4"-16NF	310 ft-lb	420 N-m
6040133-Bushing Kit	(No Pivot Hardware)			
6040078-Bushing Kit	(Huck® Hardware)	3/4"		
Fasteners	Locknut (Air Spring, Upper)	3/4"-16NF	50 ft-lb	68 N-m
	Flanged Lock Screw (Air Spring, Lower; Lift Spring)	3/8"-16NC	25 ft-lb	35 N-m
	Locknut (Steering Damper)	3/4"-10NC	160 ft-lb	217 N-m

Torque values reflect a lubricated thread condition (Nuts are pre-lubed). Do not overtorque.

CAUTION Suspension is shipped with minimal torque applied to fasteners. All fasteners must be re-torqued after first 6,000 miles of operation. Failure to install and maintain fasteners at torque specifications could result in suspension failure and void the warranty.

Vehicle Preparation

Park the vehicle on a level surface. Chock wheels to keep vehicle from moving.

Exhaust all the air from the air system. Disassemble suspension to reach pivot connections if necessary.

CAUTION Failure to chock vehicle wheels and exhaust the air system could allow vehicle/suspension movement that could result in serious injury.

Bushing Replacement Procedure.

1. Remove the pivot hardware by cutting/grinding away the Huck® Collar (Figure 4).
2. Remove bushing assembly from rod eye. Clean the rod eye of debris/corrosion.
3. Apply Energy Suspensions® Formula 5 Prelube to the bore (inside) of each bushing half.
NOTE: Do not substitute - Urethane bushing lubricant supplied with bushing kit.
4. Press bushing halves into torque rod eye until bushing half is snug against the eye.
NOTE: Mallet may be needed to install.
5. Press inner sleeve into the installed bushing opening. Check that inner sleeve is flush with both sides of installed bushing.
NOTE: Mallet or bushing press needed to insert inner bushing sleeve.
6. Install pivot hardware. Torque to specifications (Chart/Engineering drawing).
7. Reassemble suspension, if necessary. Torque to specifications (Chart/Engineering Drawing).
8. Check that the wheel toe-in setting is between 1/32" and 3/32" and adjust, if necessary (Page 5).

CAUTION Failure to torque pivot hardware can result in suspension failure and void the warranty.

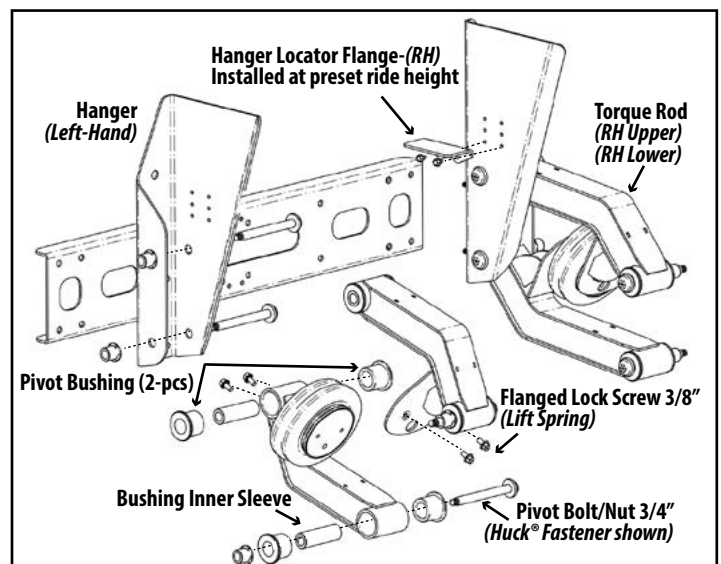
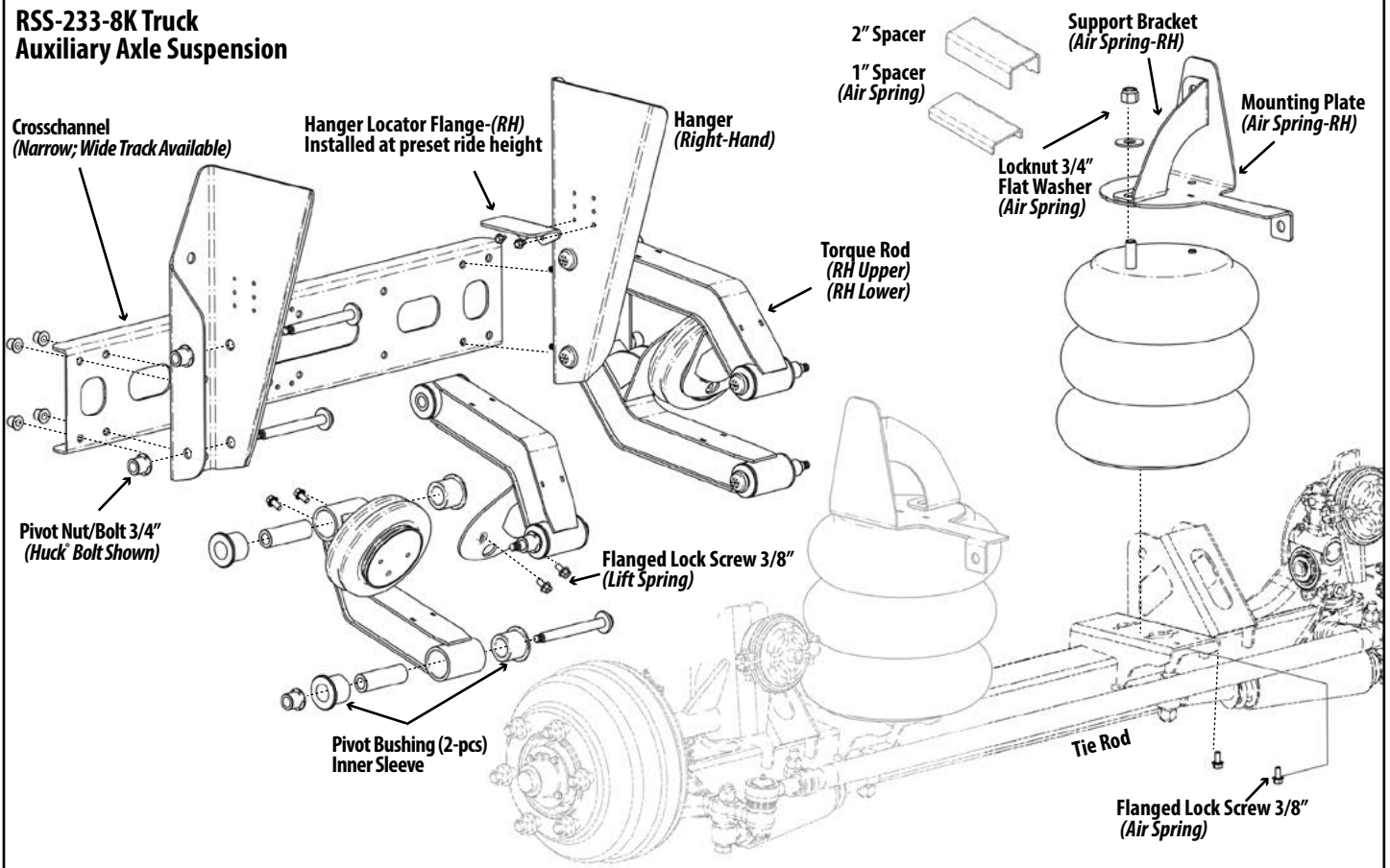

Figure 4.
Bushing replacement kits include traditional hardware components, two-piece pivot bushings and wear washers to replace eight pivot connections.

**RSS-233-8K Truck
Auxiliary Axle Suspension**



RSS-233 - 8K Truck Suspension Components (Drum Brake)

Refer to the suspension model engineering drawing for the individual component part number.

Terms and coverage in this warranty apply only to the United States and Canada.

Ridewell Suspensions warrants the suspension systems manufactured by it to be free of defects in material and workmanship. Warranty coverage applies only to suspensions that have been properly installed, maintained and operated within the rated capacity and recommended application of the suspension. The responsibility for warranty coverage is limited to the repair/replacement of suspension parts. The liability for coverage of purchased components is limited to the original warranty coverage extended by the manufacturer of the purchased part.

All work under warranty must have prior written approval from the Ridewell warranty department. Ridewell has the sole discretion and authority to approve or deny a claim and authorize the repair or replacement of suspension parts. All parts must be held until the warranty claim is closed.

Parts that need to be returned for warranty evaluation will be issued a Returned Materials Authorization (RMA). Parts must be returned to Ridewell with the transportation charges prepaid. The transportation charges will be reimbursed if the warranty claim is approved.

This non-transferable warranty is in lieu of all other expressed or implied warranties or representations, including any implied warranties of merchantability or fitness or any obligations on the part of Ridewell. Ridewell will not be liable for any business interruptions, loss of profits, personal injury, any costs of travel delays or for any other special, indirect, incidental or consequential losses, costs or damages.

Contact the Ridewell Warranty Dept. at 417.833.4565 - Ext. 135, for complete warranty information.