

# RSS-233T - 20K Trailer

## Self-Steering Air-Ride Suspension

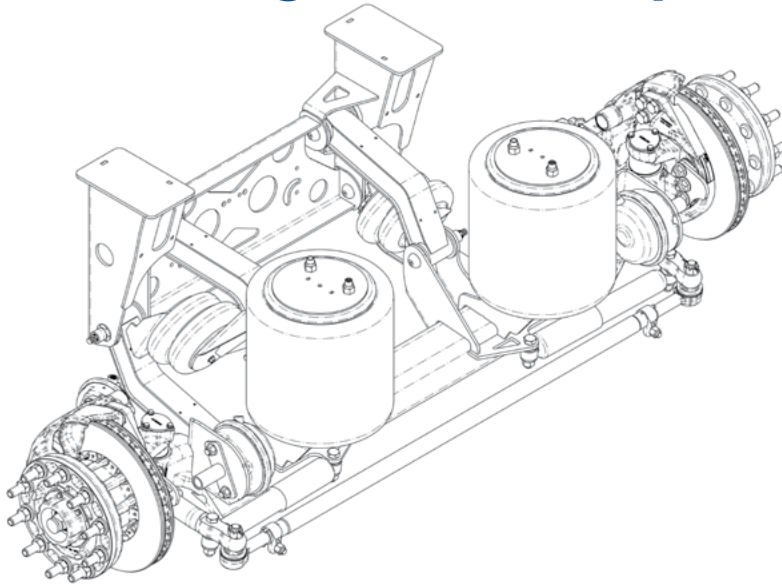

## Installation and Service Manual

<b>Suspension Identification</b> .....	<b>2</b>
<b>Prior to installation</b> .....	<b>3</b>
Suspension Mounting .....	4
Wheel Toe Setting .....	5
ACK Components - Lift Axle .....	6
Plumbing Example - Air Control Kit w/ Lift-In-Reverse system Lift Axle Control Module (LACM) with Lift-In-Reverse system .....	7
<b>Maintenance</b>	
<b>Recommended Service Intervals</b> .....	<b>8</b>
Bushing Replacement Kits/Procedure .....	9
20K Trailer Components (Drum Brake) Trailer Components (Drum Brake; Air Spring Bridge) .....	10
20K Trailer Components (Disc Brake) Trailer Components (Disc Brake; Air Spring Bridge) .....	11
<b>Warranty</b> .....	<b>12</b>





PART NO:

SUSP. NO:

SERIAL NO:

**GROSS AXLE WEIGHT RATING CERTIFICATION IS PER THE FINAL STAGE MANUFACTURER OR ALTERER.**

**THIS PRODUCT MAY BE COVERED UNDER ONE OR MORE PATENTS, ADDITIONAL PATENTS MAY BE PENDING.**

[www.ridewellcorp.com](http://www.ridewellcorp.com)

**(800) 641-4122**

### Suspension Identification Tag

The **Part Number** is listed as 606- Installation/ Assembly Number when other components are factory installed with the suspension.

The **Suspension Number** and **Serial Number** refer to the individual suspension model number and the date of its manufacture.

Refer to suspension number/part number and serial number when contacting Ridewell for customer service, replacement parts and warranty information.

### Notes and Cautions

Read through the entire Installation and Service Manual (ISM) before performing any procedures.

All work should be completed by a properly trained technician using the proper/special tools and safe work procedures.

The ISM uses two service notes to provide important safety guidelines for suspension system operation.

The service notes are defined as:

“NOTE”: Provides additional instructions or procedures to complete tasks and make sure that the suspension functions properly.

**CAUTION** Indicates a hazardous situation or unsafe practice that, if not avoided, could result in equipment damage and serious injury.



Scan/double-click QR-Code or visit the online support page at [www.ridewellcorp.com](http://www.ridewellcorp.com)

### Self-Steering Suspension Option

Steerable suspensions are designed to self-steer in the forward direction only.

The suspension must be raised off the ground or locked into a non-steering configuration during reverse travel to avoid damaging the suspension.

Use caution when maneuvering in reverse with the steering lock engaged. The driver should maintain slow maneuvering speeds and avoid extreme turns.

1. Ridewell Suspensions strongly recommends the use of automated systems that raise/lock the lift-axle during reverse travel.
2. For manual operations, Ridewell recommends the installation of a visual/audible indicator to assist the driver.

**CAUTION** Failure to lift the suspension and-or engage the steering-lock during reverse travel can cause component damage and void the warranty.

---

## Prior to installation

Refer to the suspension model engineering drawing for dimensional requirements; available ride height; and, the suspension system operating parameters.

Installations can vary. Procedures should be adapted for different vehicles, as needed.

- The Gross Axle Weight Rating (GAWR) is determined by the system component with the lowest load rating. Please consult with the tire, wheel, axle and brake manufacturers before installation to determine the GAWR.
- If vehicle chassis modifications are required, consult with the vehicle manufacturer to ensure that such changes are permitted.
- Welding or altering of suspension components is not permitted without the express written permission of Ridewell Suspensions.

## Installer Responsibilities

The installer of the suspension has the sole responsibility for proper attachment of the suspension system to the vehicle chassis.

- The installer is responsible for locating the suspension system on the vehicle to provide the proper load distribution.
- The installer must verify that vehicle crossmembers are positioned to support the suspension at the installing location.
- The installer must verify there is sufficient clearance for proper functioning of the installed auxiliary suspension – air springs; brake chambers; steering components; axle (including axle to drive-line clearance); and, tires and wheels.
- It is the installer's responsibility to determine that axle spacing conforms to any applicable federal and local bridge laws.
- The installer must verify that air reservoir volume requirements are met after suspension installation. Consult the vehicle manufacturer or Federal Motor Vehicle Safety Standards (FMVSS) 121 for more information.

## Suspension Mounting

Refer to the suspension model engineering drawing for the suspension travel table; torque specifications; and, the spacing and clearance requirements for mounting the suspension.

### Weld-On Installation Procedure

The RSS-233T 20K Trailer Suspension is shipped fully assembled. The components must be reassembled with the proper torque applied if the system is taken apart for installation (Page 9).

Recommended locations of customer-furnished filler plates and supporting crossmembers for hangers and air spring mounting plates are shown on the engineering drawing.

**CAUTION** The welding method used must develop a minimum weld tensile strength of 70,000 psi per AWS specifications.

1. Mark the desired location for the frame hangers and air spring mounting plates and customer-furnished filler plates on the frame.  
NOTE: For proper support, a crossmember must be located within six inches of the leading or trailing edge of the frame hanger.
2. Check the location for sufficient clearances in both the raised and lowered positions.
3. Weld customer-furnished filler plates, as needed, to crossmembers with ¼" fillet welds down the length of the crossmember.
4. Weld customer-furnished filler plates for air spring mounting plates to frame and crossmember(s). Weld filler plates with ¼" fillet welds down the length of crossmember.
5. Weld the hangers to the frame/filler plates with ¼" fillet welds completely around the hangers. Stop the welds ½" from the corners and edges.
6. Weld the air spring mounting plates to the frame/filler plates with 3/16" fillet welds all the way around the mounting plates/bridge assembly.
7. If components have been removed for installation, reinstall as shown on engineering drawing. Torque to specifications (Page 9).
8. Install/connect the air control kit (ACK) to the suspension. Check the air system installation for leaks and proper operation of controls (Page 6).
9. Perform final assembly and inspection and check the wheel toe setting (Page 5).

### Bolt-On Installation Procedure

Grade-8 bolts, flanged locknuts or locknuts with hardened washers are supplied by the installer.

Refer to the engineering drawing for the range of available ride heights; spacing and clearance requirements; and, bolting pattern detail of the suspension.

Verify that wires, hoses or other components located within the frame rail are not affected by drilling.

**CAUTION** If recommended bolt-hole locations are not available, locate and drill bolt-holes as far apart as possible to provide the most support for the assembled suspension.

Failure to torque components to specifications can result in suspension failure and void the warranty.

### Final Assembly and Inspection

1. Verify welds on hangers and air spring mounting plates. Verify all suspension components are torqued to specifications (Page 9).
2. Install wheels and tires.  
**CAUTION** When lowering an auxiliary axle on an unloaded vehicle, pressure to the load air springs must be reduced to below 10 psi.  
Failure to reduce air pressure could cause the vehicle's axles to rise from the ground and the vehicle could roll in an unsafe manner.
3. Check that tires are inflated to recommended pressure. Check wheel hubs for proper level of lubricant recommended by the manufacturer.
4. Lift the axle to the raised position. Check the air system tubing and connections for leaks.
5. Check that wheels can rotate freely and that brakes and slack adjusters are properly adjusted.
6. Raise and lower suspension assembly (wheels and tires installed) through entire range of travel. Verify sufficient clearances for air springs, brake chambers and other components.
7. Check the vehicle's reverse travel options:
  - 7.1. Check steer lock operation.
  - 7.2. Check automated system (if installed) to make sure that suspension raises/locks wheels during reverse travel.  
**CAUTION** Failure to check reverse travel operations can result in component damage and void the suspension warranty.
8. Verify wheel toe-in setting between 1/32" and 3/32". Adjust if necessary (Page 5).





## Air Control Kit Components - Lift Axle

The air control kit (ACK) consists of a pressure regulator with a gauge connected to an air valve controlled by a manual knob or an electric switch. The operator uses the ACK to control the pressure to the air springs to support different loads.

**CAUTION** The installer is responsible for making sure that air system requirements comply with the appropriate Federal Motor Vehicle Safety Standards.

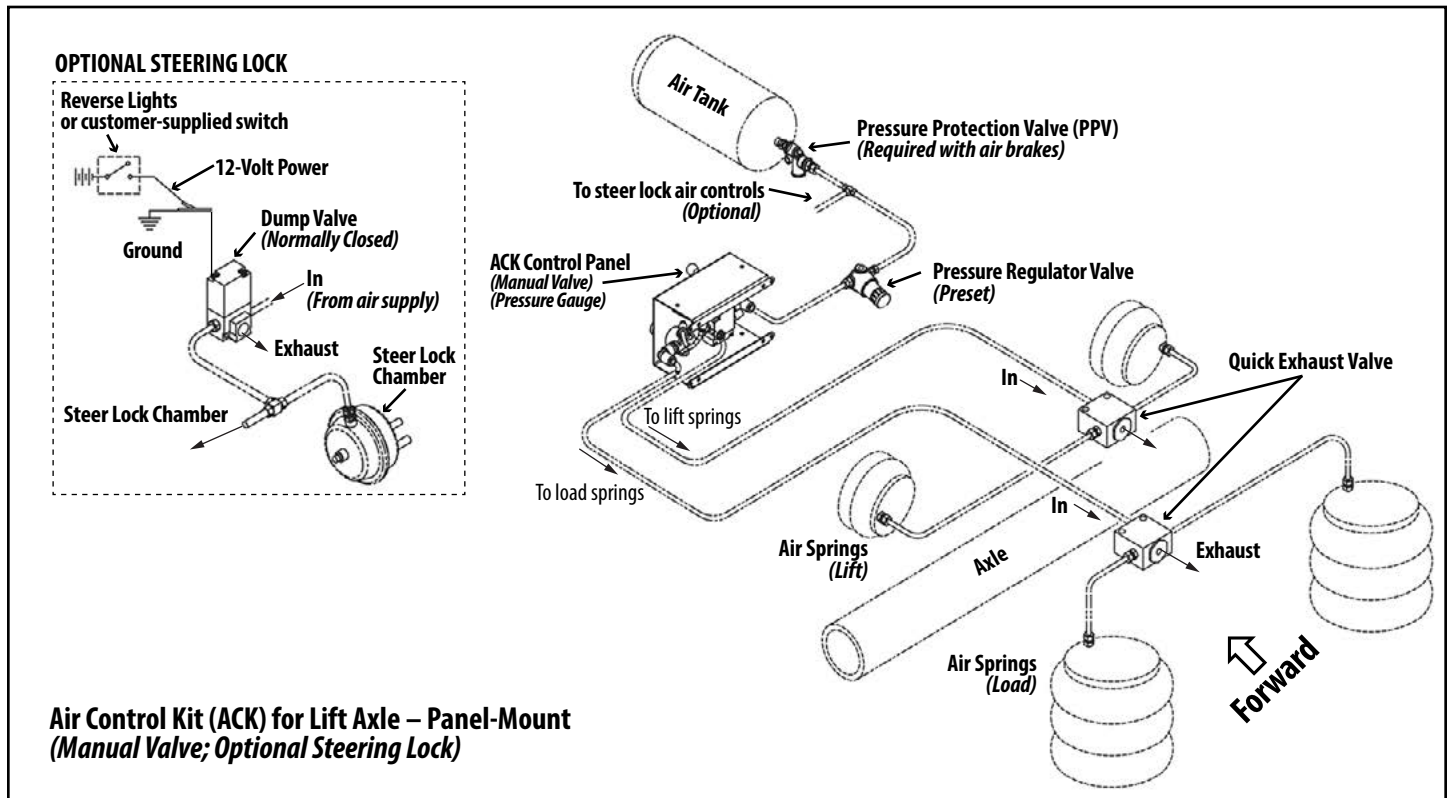

## TROUBLESHOOTING – AIR CONTROL KIT

Problem	Possible Cause	Solution
<b>Air springs fill but do not exhaust.</b>	<ul style="list-style-type: none"> <li>– Obstructed air line.</li> <li>– Faulty controls wiring.</li> <li>– Manual override pushed in.</li> </ul>	<ul style="list-style-type: none"> <li>– Check for pinched/blocked lines.</li> <li>– Check wiring w/ voltmeter. Correct wiring/installation.</li> <li>– Release manual override.</li> </ul>
<b>Air system leaks down after a short period of time.</b>	<ul style="list-style-type: none"> <li>– Leak in air system beyond accepted standards. NOTE: Some valves will leak at an acceptable rate.</li> </ul>	<ul style="list-style-type: none"> <li>– Pressurize system and spray soapy water solution onto tubing, valves and fittings. Check for bubbles (leaks).</li> <li>– Check that tubing cuts are straight and smooth. Re-cut and reassemble fitting joints, if necessary.</li> </ul>
<b>Auxiliary unit will not stay up</b>	<ul style="list-style-type: none"> <li>– Loose air fitting connection/Damaged air lines.</li> <li>– Air lines to lift and load air springs are reversed.</li> <li>– Damaged or worn air springs.</li> </ul>	<ul style="list-style-type: none"> <li>– Check and retighten fittings. Repair or replace component, as necessary.</li> <li>– Check installation. Air line from regulator goes to (load) air springs.</li> <li>– Replace air spring if worn or damaged.</li> </ul>
<b>Auxiliary unit not achieving correct lift</b>	<ul style="list-style-type: none"> <li>– Air lines to lift and load air springs are reversed.</li> <li>– Lift air springs do not have proper air pressure.</li> <li>– Interference with driveline/other chassis components.</li> <li>– Air control system not installed correctly.</li> </ul>	<ul style="list-style-type: none"> <li>– Check installation. Air line from regulator goes to (load) air springs.</li> <li>– Check for loose fittings or worn/damaged lines. Verify air tank pressure with gauge.</li> <li>– Visually inspect auxiliary unit operation for proper clearance. Retighten any loose fasteners.</li> <li>– Check air control kit installation; refer to OEM installation procedures.</li> </ul>

**Panel-Mount ACK for Lift Axle w/ Lift-In-Reverse**  
*(Electric Valve; Optional Steering Lock)*

**Lift-In-Reverse-Wiring Diagram**

Note: Relay is required only for lift-in-reverse operation

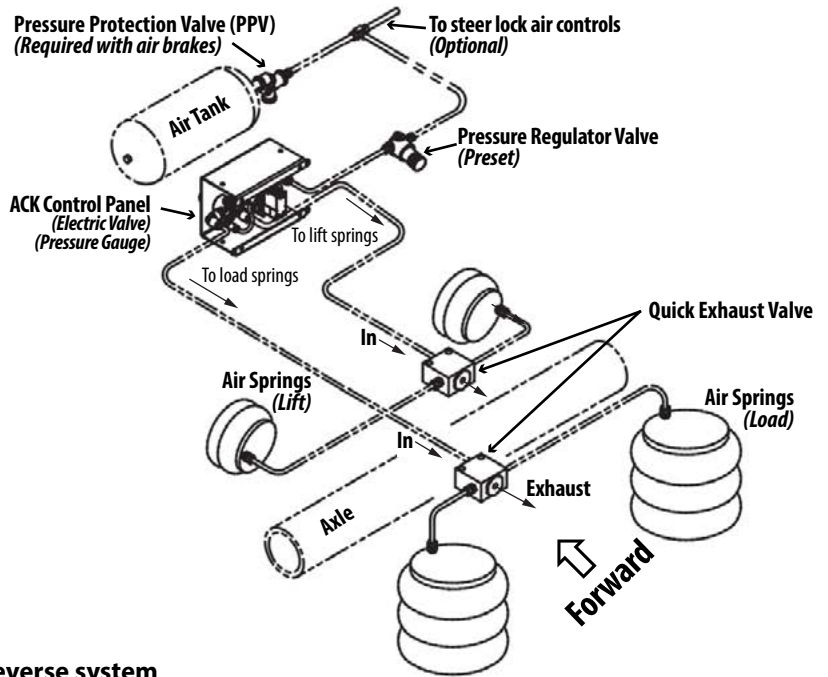
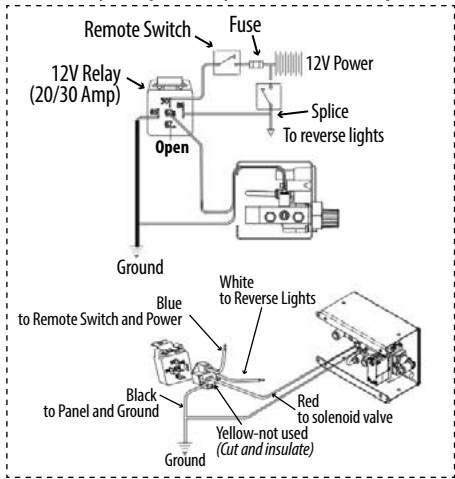
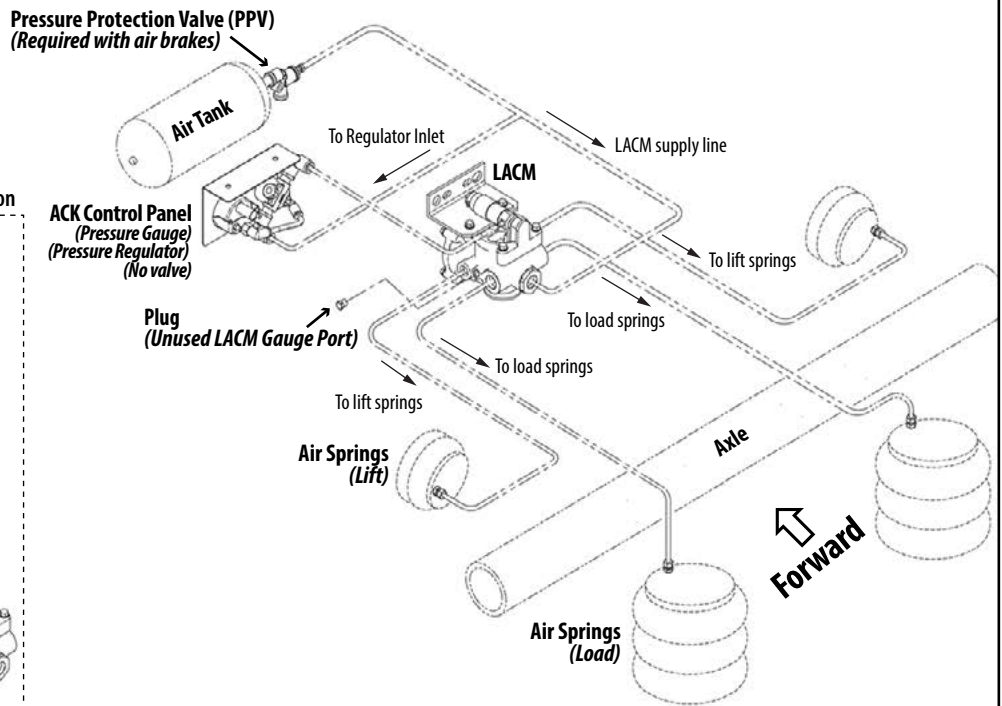
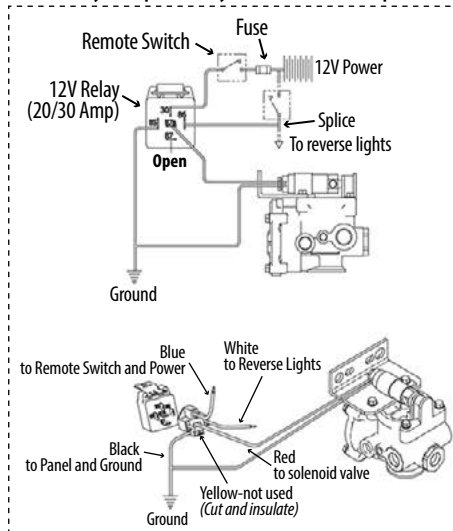

**Figure 1.**  
**Plumbing Example - Air Control Kit w/ Lift-In-Reverse system**

**ACK-Lift Axle Control Module with Lift-In-Reverse**

**Lift-In-Reverse-Wiring Diagram**

Note: Relay is required only for lift-in-reverse operation



**Figure 2.**  
**Plumbing Example - Lift Axle Control Module (LACM) with Lift-In-Reverse system**

**Recommended Service Intervals**

Ridewell Suspensions recommends these minimum service intervals for standard duty, on-highway usage suspension applications.

More frequent service intervals are recommended for off-highway/heavier duty applications.

**Daily/Pre-Trip Inspections**

- \_\_\_ Visually inspect suspension structure for signs of damage or excessive wear.
- \_\_\_ Check for loose or missing bolts/nuts. Check for irregular movement in suspension system components.
- \_\_\_ Check tires for proper inflation, road damage or excessive wear.
- \_\_\_ Check wheel-ends for obvious signs of lubricant leakage. Check for missing components.
- \_\_\_ Make sure air controls are operating properly. Drain all moisture from air reservoirs.

**First 6,000 miles of use**

- \_\_\_ Torque all bolts/nuts to specifications (Page 9).

**Every 12,000 miles of use**

- \_\_\_ Lubricate Brake Cam and Slack Adjuster.
- \_\_\_ Grease kingpin thrust bearings. Apply grease in upper and lower grease fittings until new grease is visible at the purge location. Wipe the excess grease from purge areas and grease fittings.
- \_\_\_ Inspect steering damper for damage/wear.
- \_\_\_ Inspect air springs for damage/excessive wear. Torque bolts/nuts to specifications (Page 9).
- \_\_\_ Check air system for leaks.

**First 50,000 miles of use**

- \_\_\_ Check wheel-end/knuckle for excessive play.
- \_\_\_ Inspect tie-rod and tie-rod ends for excessive damage/wear. Lubricate tie-rod ends. Verify tie-rod boot is in place and completely over the end of tie-rod. Replace entire tie-rod end if boot is damaged.
- \_\_\_ Check pivot bushings for wear.
- \_\_\_ Torque all suspension system component bolts/nuts to specifications (Page 9).
- \_\_\_ Check (reverse) steer lock operation (if equipped).
- \_\_\_ Verify operation of manual/automatic lift-in-reverse control system (if equipped).

**Annual/100,000 Miles Inspection**

- \_\_\_ Inspect pivot connections for worn bushings/wear washers. Replace if necessary. Torque pivot hardware to specifications (Page 9).
- \_\_\_ Check lubrication level in wheel-ends. Refill/Replace lubricant as needed. *(TMC RP 631-Wheel End Lubrication Procedure)*
- \_\_\_ Check frame hanger and air spring mounting plate connections to frame.
- \_\_\_ Check air system for leaks.
- \_\_\_ Test air tank pressure protection valve (PPV) if equipped.
- \_\_\_ Check brakes/brake chambers for damage/function.

**⚠CAUTION** Failure to exhaust all pressure from the air system before vehicle work can cause serious injury.

**⚠CAUTION** Failure to torque suspension components to specifications can result in suspension failure and void the warranty.

**Refer to these Technology & Maintenance Council (TMC) Recommended Procedures for additional information:**

RP 609	Self-Adjusting/Manual Brake Adjuster Removal, Installation and Maintenance
RP 618	Wheel Bearing Adjustment Procedure
RP 619	Air System Inspection Procedure
RP 622	Wheel Seal and Bearing Maintenance
RP 631	Wheel End Lubrication Procedures
RP 643	Air Ride Suspension Maintenance Guidelines
RP 645	Tie-Rod End Inspection/Maintenance
RP 651	Steer Axle Maintenance Guidelines

**Available Wheel-End Lubricants**

Lubricant Type	Part No.	Item Description
Mineral Oil	<b>380008G</b>	(CITGO) MP GearOil 631310001-80W-90
Synthetic Oil	<b>1980006</b>	(SHELL) Synthetic API GI-5 75W-90 Oil
Synthetic Hard-Pack Grease	<b>1980007</b>	(CITGO) Synthetic Grease



## 233T-20K TRAILER SUSPENSION — BUSHING REPLACEMENT KITS/TORQUE SPECIFICATIONS

Part Number (Component)	Item Description	Size	Torque Values	
			foot-pound	Newton-meter
6040161 - Bushing Kit	Traditional Hardware (HHCS/Locknut)	7/8"-14NC	500 ft-lb	678 N-m
6040160 - Bushing Kit	(No Pivot Hardware)	—		
<b>Fasteners</b>	Locknut - (Air Spring, Upper)	3/4"-16NF	50 ft-lb	68 N-m
	Bolt/Lock Washer (Air Spring, Lower)	1/2"-13NC	50 ft-lb	68 N-m
	Locknut - (Lift Spring, Inner)	3/4"-16NF	50 ft-lb	68 N-m
	Locknut - (Lift Spring, Outer)	1/2"-20NF	25 ft-lb	34 N-m
	Flanged Lock Screw (Lift Spring)	3/8"-16NC	25 ft-lb	34 N-m
	Locknut - (Tie Rod/Steering Damper)	3/4"-10NC	160 ft-lb	217 N-m
	Locknut - (Crosschannel)	5/8"-11NC	160 ft-lb	217 N-m

Torque values reflect a lubricated thread condition (Nuts are pre-lubed). Do not overtorque.

**CAUTION** Suspension is shipped with minimal torque applied to fasteners. All fasteners must be re-torqued after first 6,000 miles of operation. Failure to install and maintain fasteners at torque specifications could result in suspension failure and void the warranty.

### Vehicle Preparation

Park the vehicle on a level surface. Chock wheels to keep vehicle from moving.

Exhaust all the air from the air system. Disassemble suspension, if needed, to reach the pivot connections.

**CAUTION** Failure to properly chock wheels and exhaust the air system could allow vehicle movement that could result in serious injury.

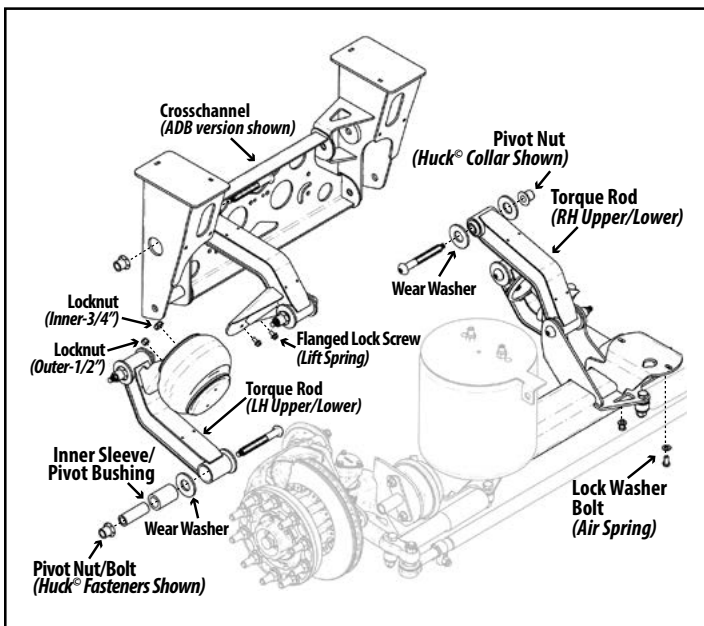
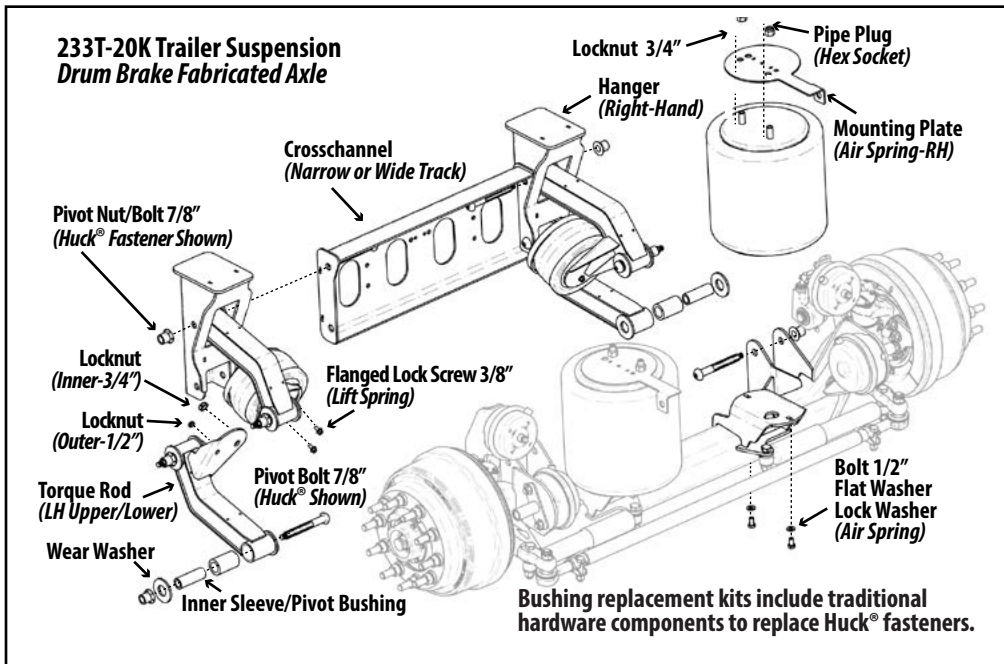

**Figure 3.** Traditional hardware and wear washers for eight pivot connections included in bushing replacement kit.

### Bushing Replacement Procedure

1. Cut/grind away Huck® Collar. Take pivot connection apart. Discard pivot hardware. Discard wear washers (Figure 3).
2. Remove bushing assembly from the torque rod and discard. Clean the rod eye of any foreign debris or corrosion.
3. Apply Energy Suspensions® Formula 5 Prelube to the bore (inside) of new bushings.  
NOTE: Do not substitute - special urethane bushing lubricant included with all bushing kits.
4. Install bushing in the eye of the torque rod.  
NOTE: Mallet/press may be needed to install new bushing and sleeve.
5. Press inner sleeve into the installed bushing. Center the sleeve inside the bushing so that both ends extend slightly past the sides of the bushing.
6. Assemble the pivot connection with one wear washer on each side of the bushing. The inner sleeve of the bushing must be flush with or extend slightly past the outside of the wear washers after assembly (Figure 3).
7. Torque pivot nut to specifications (500 ft-lb-678 N-m).
8. Reassemble suspension components, if necessary. Tighten components to specifications (Chart/Engineering Drawing).
9. Check wheel toe-in setting (between 1/32" and 3/32") and adjust, if necessary.

**CAUTION** Failure to torque pivot hardware can result in suspension failure and void the warranty.



**Figure 4.**  
**20K Trailer Components**  
**(Drum Brake)**  
Refer to the Narrow- or Wide-Track Steer Lock version of engineering drawing for the component part number.

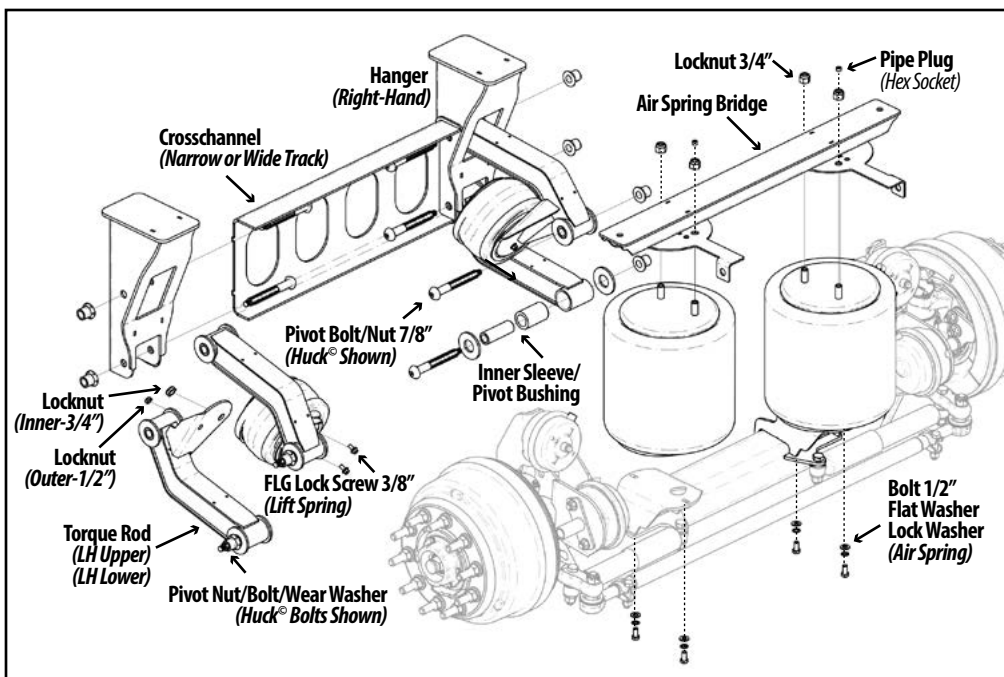

**Figure 5.**  
**20K Trailer Components**  
**(Drum Brake; Air Spring Bridge)**

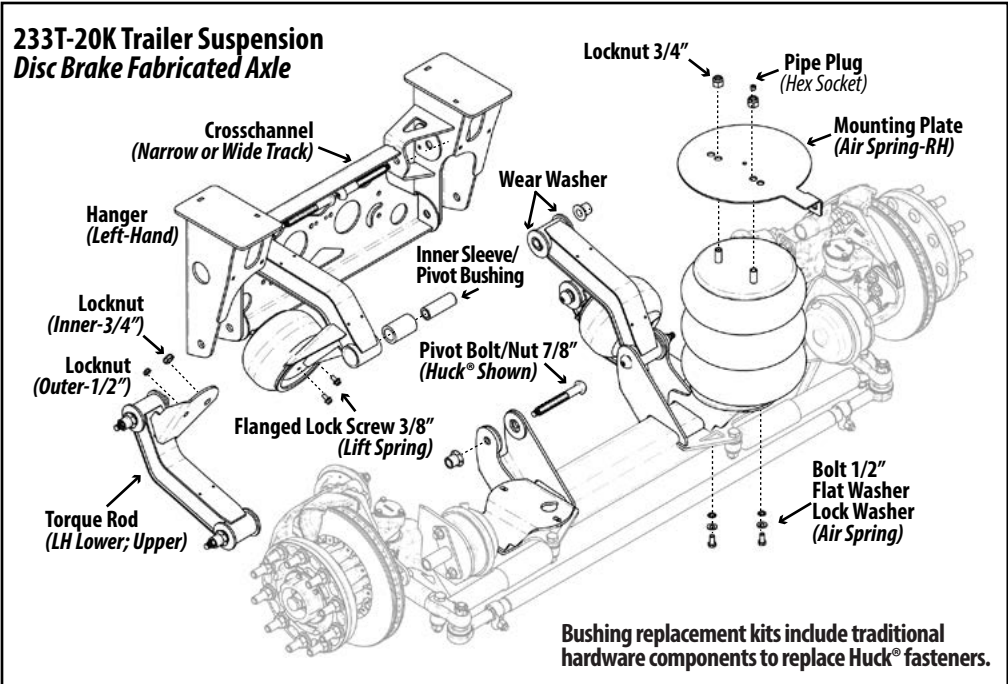

**Figure 6.**  
**20K Trailer Components**  
**(Disc Brake)**  
 Refer to the Narrow- or Wide-Track Steer Lock version of engineering drawing for the component part number.

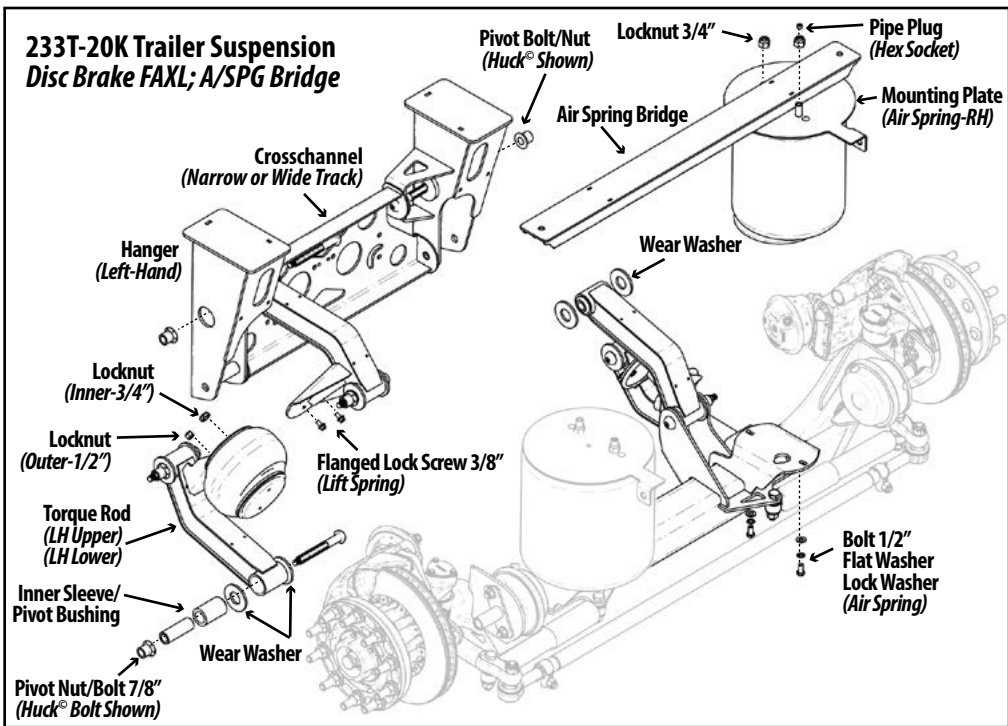

**Figure 7.**  
**20K Trailer Components**  
**(Disc Brake; Air Spring Bridge)**

**Terms and coverage in this warranty apply only to the United States and Canada.**

Ridewell Suspensions warrants the suspension systems manufactured by it to be free of defects in material and workmanship. Warranty coverage applies only to suspensions that have been properly installed, maintained and operated within the rated capacity and recommended application of the suspension. The responsibility for warranty coverage is limited to the repair/replacement of suspension parts. The liability for coverage of purchased components is limited to the original warranty coverage extended by the manufacturer of the purchased part.

All work under warranty must have prior written approval from the Ridewell warranty department. Ridewell has the sole discretion and authority to approve or deny a claim and authorize the repair or replacement of suspension parts. All parts must be held until the warranty claim is closed.

Parts that need to be returned for warranty evaluation will be issued a Returned Materials Authorization (RMA). Parts must be returned to Ridewell with the transportation charges prepaid. The transportation charges will be reimbursed if the warranty claim is approved.

This non-transferable warranty is in lieu of all other expressed or implied warranties or representations, including any implied warranties of merchantability or fitness or any obligations on the part of Ridewell. Ridewell will not be liable for any business interruptions, loss of profits, personal injury, any costs of travel delays or for any other special, indirect, incidental or consequential losses, costs or damages.

**Contact the Ridewell Warranty Dept. at 417.833.4565 - Ext. 135, for complete warranty information.**