

---

# RAR-243

## *Air Ride Trailer Suspension*

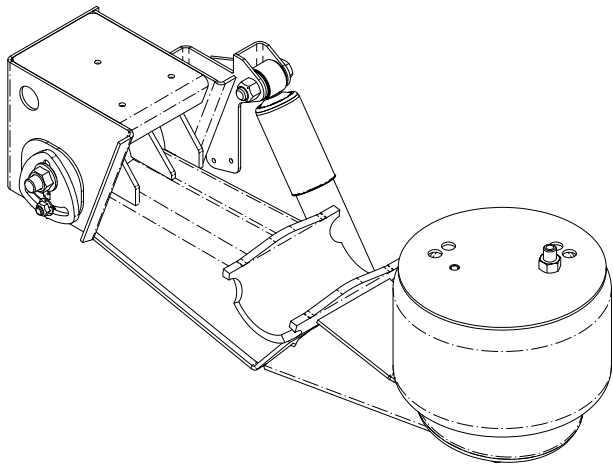

## Installation and Service Manual

<b>Suspension Identification</b> .....	<b>2</b>
<b>Prior to Installation</b> .....	<b>3</b>
<b>Axle Integration</b> .....	<b>4</b>
<b>Suspension Mounting</b> .....	<b>6</b>
<b>HCK Troubleshooting</b> .....	<b>7</b>
<b>Maintenance</b>	
<b>Recommended Service Intervals</b> .....	<b>8</b>
<b>Trailer Suspension Components</b> .....	<b>9</b>
<b>Bushing Replacement Kit/Procedure</b> .....	<b>10</b>
<b>Axle Alignment</b> .....	<b>11</b>
<b>Warranty</b> .....	<b>12</b>

**Introduction**

The Ridewell Air Ride (RAR) 243 suspension is designed to accommodate a range of ride heights for each specific model. Used for various applications, the suspension can be purchased with or without an integrated axle.

 <b>RIDEWELL SUSPENSIONS</b> The Engineered Suspension Company	
PART NO:	
SUSP. NO:	
SERIAL NO:	
<b>GROSS AXLE WEIGHT RATING CERTIFICATION IS PER THE FINAL STAGE MANUFACTURER OR ALTERER.</b> <b>THIS PRODUCT MAY BE COVERED UNDER ONE OR MORE PATENTS, ADDITIONAL PATENTS MAY BE PENDING.</b> <b>www.ridewellcorp.com (800) 641-4122</b>	

**Suspension Identification Tag**

A (606-) **Installation/Assembly Number** is listed as the **Part Number** when other system components are factory installed with the suspension (Figure 1).

The **Suspension Number** and **Serial Number** on the Suspension ID Tag refer to the model and the date of manufacture of an individual suspension system.

Please refer to the suspension number/part number and serial number on the Suspension Identification Tag when contacting Ridewell for customer service, replacement parts and warranty information.

 <b>RIDEWELL SUSPENSIONS</b>			
MODEL:		PART NO.	
SERIAL NO.		CAPACITY	TON

**Axle-Body Identification Tag**

The **Base-Axle Part Number (165-)** and the **Serial Number** of the axle tube are listed on the Axle-Body ID Tag of Ridewell-branded round axles (Figure 2).

The **Base-Axle Part Number** refers to Ridewell-branded round axles manufactured in various axle wall thicknesses and widths.

More information on Ridewell-branded axles can be found in the "Trailer Axle Parts Guide" (9710029).



**Notes and Cautions**

All work should be completed by a properly trained technician using the proper/special tools and safe work procedures.

Read through the entire Installation and Service Manual (ISM) before performing any installation or maintenance procedures.

The ISM uses two types of service notes to provide important safety guidelines, prevent equipment damage and make sure that the suspension system operates correctly. The service notes are defined as:

“NOTE”: Provides additional instructions or procedures to complete tasks and make sure that the suspension functions properly.

**CAUTION** Indicates a hazardous situation or unsafe practice that, if not avoided, could result in equipment damage and serious injury.

## Prior to Installation

Refer to the suspension model engineering drawing for detailed information on system components; the range of available ride heights; dimensional requirements; and, operating parameters.

The suspension is designed to fit up onto standard I-beam trailer frames at beam centers that correspond to standard axle track widths (Chart).

Installation at wider beam centers will reduce suspension clearances. Installation at narrower beam centers will de-rate the axle beam capacity.

For non-standard beam centers, frames, frame centers, axle track widths and wheel-end equipment, the installer is responsible for verifying clearances, axle capacity, proper fit-up, and any additional required support structure.

Installations can vary and procedures should be adapted for different vehicles as needed.

- The Gross Axle Weight Rating (GAWR) is determined by the system component with the lowest load rating. Please consult with tire, wheel, axle and brake manufacturers before installation to determine the GAWR.
- If vehicle chassis modifications are required, consult with the vehicle manufacturer to ensure that such changes are permitted.
- Welding or altering suspension components is not permitted without the express written permission of Ridewell Suspensions.

## Installer Responsibilities

The installer of the suspension has the sole responsibility for proper attachment of the suspension system to the vehicle chassis.

- The installer is responsible for locating the suspension system on the vehicle to provide the proper load distribution.
- The installer must verify that vehicle crossmembers are positioned to support the suspension at the installing location.
- It is the installer's responsibility to determine that axle spacing conforms to any applicable federal and local bridge laws.
- The installer must verify that air reservoir volume requirements are met after installation. Consult the vehicle manufacturer or Federal Motor Vehicle Safety Standards (FMVSS) 121 for more information.
- The installer must verify there is sufficient clearance for proper functioning of the suspension, air springs, brake chambers, axle and tires.

Standard Trailer Dimensions				
Trailer	Track Width	Frame Center	Beam Center	Air Spring Center
96"	71.5"	38"	35"	31"
102"	77.5"	44"	41"	37"

## Axle Integration

Suspension systems are available with and without a factory integrated axle. Customer-supplied axle assemblies must be positioned and oriented (rotated) properly before welding the axle to the axle seats.

Use the top-center mark on the axle, if available, to identify the center of the axle and orient the axle assembly on the suspension.

The axle assembly should be installed so that the camshafts, when activated, rotate in the same direction as the wheels.

**⚠CAUTION** Failure to follow procedures and design specifications could result in injury, damage to the axle or suspension and void the warranty.

### Weld Preparation

The joint to be welded should be positioned in the flat or horizontal position. All grease, dirt, paint, slag or other contaminants must be removed from the weld joint.

The axle and suspension components should be at a minimum temperature of 60°F (15.5°C). Pre-heat the weld zone to the axle manufacturer's recommended pre-heat temperature, if required.

### Weld Procedure

Ridewell recommends supporting the axle and suspension with a weld fixture during axle integration. Contact Ridewell Customer Service for the correct weld fixture for your suspension model.

1. Center the axle assembly on the beam centers (Figure 1).
2. Check the engineering drawing for the brake component orientation (rotation) before clamping into place and making the final welds.
  - 2.1. Drum brake camshafts are spaced off the tail of the trailing arm beam. Make sure the brake chamber brackets are oriented properly and clamp the axle assembly into place.
  - 2.2. Disc brake assemblies have a right- and left-hand caliper assembly. Make sure the callipers are located on the correct side and rotated to the proper position before clamping the axle assembly into place.
3. Check the gap between the axle and the axle seats before welding (Figure 2). Side gaps should be no greater than 1/8". The gap at the bottom of the axle seat should be no greater than 1/16".
4. Weld the axle to the seat according to Ridewell Weld Process #1 (Page 5).

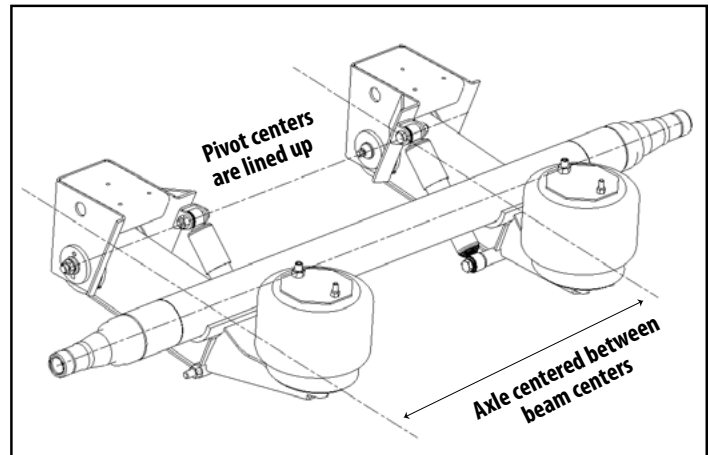

**Figure 1.**  
Axle centered between beams with beams and axle perpendicular to each other. Refer to the engineering drawing for measurements.

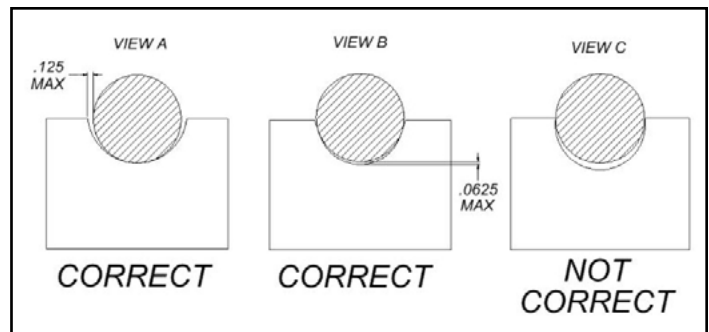

**Figure 2.**  
Correct axle tube seating for welding.

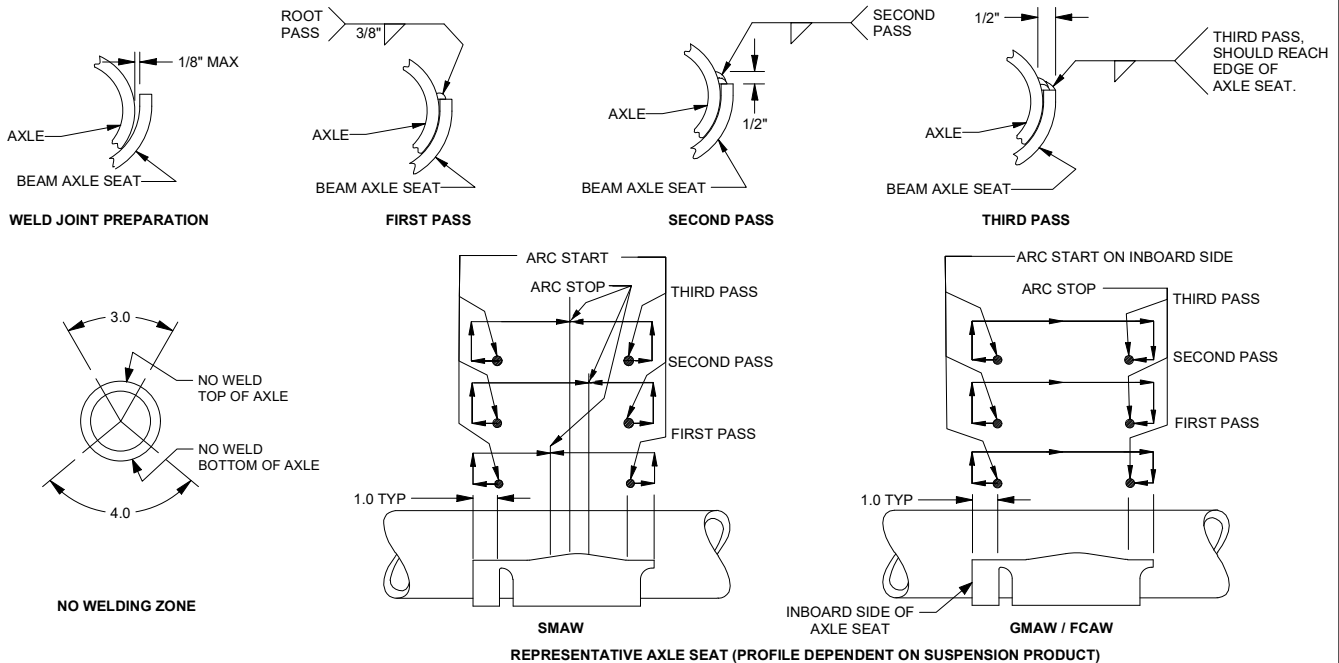

- CAUTION:** All welds must be kept away from the top and bottom of the axle where maximum stresses occur (see "NO WELDING ZONE" illustration above). Do not test-weld the arc on any part of the axle tube.
- All welders and welding operators should be certified as per the requirements of the American Welding Society (AWS) or equivalent. All electrodes used should meet the AWS specifications and classifications for welding carbon and low-alloy steels.
- Recommended Welding Methods:** Shielded Metal Arc Welding (SMAW), Gas Metal Arc Welding (GMAW) or Flux Cored Arc Welding (FCAW). The welding method used and the electrode selected must develop a minimum weld tensile strength of 70,000 psi per AWS specifications. The best fusion and mechanical properties will be obtained by using the voltage, current, and shielding medium recommended by the electrode manufacturer. If the SMAW method is used, the stick electrodes must be new, dry, free of contaminants and stored per AWS specifications.
- Weld Joint Preparation:** The joint to be welded should be positioned in the flat or horizontal position. All grease, dirt, paint, slag or other contaminants must be removed from the weld joint without gouging the axle tube. It is recommended that paint be removed a minimum of 2" away from the weld joint. **CAUTION:** Never weld when the axle is cold. The axle and beam assemblies to be welded should be at a temperature of at least 60°F (15°C). Pre-heat the weld zone to the axle manufacturer's recommended pre-heat temperature, if required. This will reduce the chance of an area of brittle material forming adjacent to the weld.
- The axle should fit into the beam assembly with a maximum root gap of 1/8-inch between the axle and the beam axle seat (see "WELD JOINT PREPARATION" illustration above). The root gap should be as equal as possible on each side of the beam axle seat. The axle must be centered laterally in the beams.
- NOTE:** Clamp the axle to the beam axle seat with a C-clamp prior to welding to make sure that proper contact occurs (see "CORRECT" illustration below).
- Ground the axle to one of the attached axle parts such as the brake chamber brackets, cam brackets or brake spider. Never ground the axle to a wheel or a hub as the spindle bearing may sustain damage.
- Multiple pass welding should be used on the beam/axle connection using the following guidelines:
  - Total fillet weld size should be 1/2-inch.
  - Weld pass starts and stops should be performed as illustrated above.
  - Never start or stop welds at the end of the weld joint.
  - Each pass must be accomplished in one or two segments.
  - Start welds at least 1-inch from the end and backweld over the start. Backstep fill all craters.
  - If process is not GMAW all slag must be removed between passes.
  - Welds must go to within 1/8-inch +/- 1/16-inch of the ends of the axle seat and must not go beyond or around the ends of the axle seat.
  - Post-weld peening is recommended, but not required: Needle peen the entire toe of the second pass, including around the ends of the axle seat. Hold the needles perpendicular to the axle. A uniform dimpled pattern will appear when properly peened.

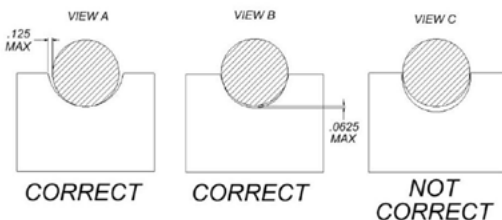

J	23101	ADDED 9710039 TO DRAWING NUMBER	11/13/23	AAS	BB	CJB
REV	PROJ/ECR	DESCRIPTION	DATE	BY	CHK	APPD
DRAWN BY:	CBC	11/13/2023	 <b>RIDEWELL CORPORATION</b> PO BOX 4586 SPRINGFIELD, MISSOURI 65808			
CHECKED:	MDJ	2/21/2003				
APPROVED:	CJB	2/21/2003				
PROJECT NO:	03103	SCALE: A-SIZE: NTS	<b>TITLE:</b> <b>RIDEWELL WELD PROCESS #1,          5" DIA. AXLE, 3 PASS WELD</b>			
MATERIAL:	-	WEIGHT:				
SHEET 1 OF 1			PART NO:	9710039-WELD PROCESS No1		REV: J

UNCONTROLLED IF PRINTED

## Suspension Mounting

Refer to the engineering drawing for the range of ride heights available, torque values, spacing and clearance requirements of the suspension.

Recommended locations of customer-furnished filler plates and supporting crossmembers for the suspension hangers and air spring mounting plates are shown on the engineering drawing.

The suspension installer has the final responsibility of attaching the suspension to the vehicle frame.

### Weld-On Installation Procedure

**CAUTION** Welding method must use a minimum weld tensile strength of 70,000 psi, per AWS specifications.

1. Mark the desired location of the hangers and filler plates on the vehicle frame. Hangers must be installed parallel to each other for proper axle alignment.
2. Mark the desired location of the air spring mounting plates and filler plates on the frame.
3. Install filler plates for the hangers and air spring mounting plates on the frame. Weld filler plates to crossmembers with 1/4" fillet welds down the length of the crossmember.
4. Weld the hangers to the frame/filler plates with 1/4" fillet welds completely around the hangers. Stop the welds 1/2" from the corners and edges.
  - 4.1. For hangers with wing gussets, the wing gussets must be welded to a crossmember or other supporting structure.
  - 4.2. A length of 1 1/2"-diameter pipe can be placed through the holes in the two hangers to help with stabilization and alignment.
5. Weld the air spring mounting plates to the frame/filler plates with 3/16" fillet welds.
6. Attach a crossmember or diagonal brace to the front of the hangers with 1/4" fillet welds.

### Bolt-On Installation

Before installation, check to make sure that wires, hoses or other components will not be affected by drilling into the frame rail.

Bolts/nuts for attaching the suspension to the vehicle are supplied by the installer. Grade 8 bolts and flanged locknuts or locknuts with hardened washers are recommended.

Bolt holes are not provided in the air spring mounting plates. Clamp mounting plates and filler plates (if necessary) in place before drilling.

### Final Assembly and Inspection

- Verify the welds of the hanger and air spring mounting plates.
- Check the location for sufficient clearances of suspension components.
- Attach beam and axle assemblies to hangers. Note: Do not fully torque pivot hardware until axle alignment is completed (Page 11).

**CAUTION** Do not apply undercoating; paint or other top coat to suspension; frame hangers; or pivot connection hardware until axle alignment procedure is completed.
- NOTE: Areas where metal surfaces of alignment plates; washers; pivot bolts/nuts or pivot bushing (bushing sleeve) contact the frame hanger must be masked if applying under- or top coating prior to suspension assembly (Figure 3).

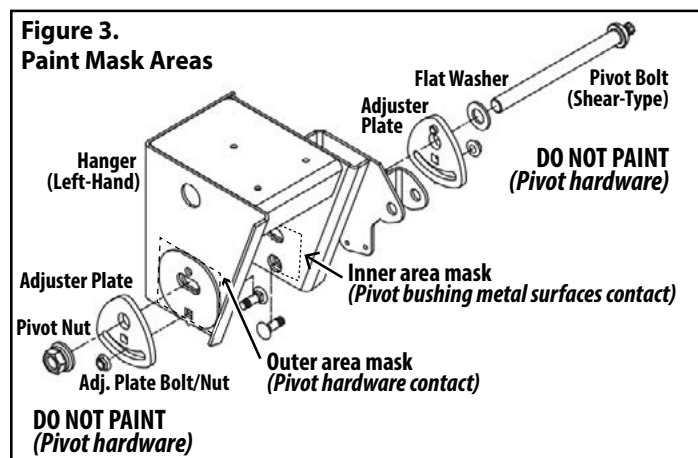

- Complete assembly and installation of air springs as shown on the engineering drawing. Torque to specifications (Page 10).
- Install/connect the height control valve (HCV), if applicable (Page 7). Check the air system tubing and fittings after installation for leaks.
- Verify the suspension ride height is adjusted within the range shown on the engineering drawing and complete axle alignment procedure (Page 11).
- Install shock absorbers. NOTE: If the suspension is painted after shocks are installed, make sure paint overspray does not get under the shock absorber dust covers.

**CAUTION** Failure to torque bolts/nuts of suspension components to specifications can result in failure of the suspension and void the warranty.

The Ridewell Extreme Air® Height Control Kit (HCK) adds and exhausts air from the air springs to maintain vehicle ride height. The HCK assembly consists of one lever connected to the height control valve (HCV) with a rod arm (vertical link) connected to the lower mounting bracket (Figure 4).

The vehicle's entire air system should be checked for leaks after any height control kit installation.

**CAUTION** The installer is responsible for making sure the air system requirements comply with all appropriate Federal Motor Vehicle Safety Standards.

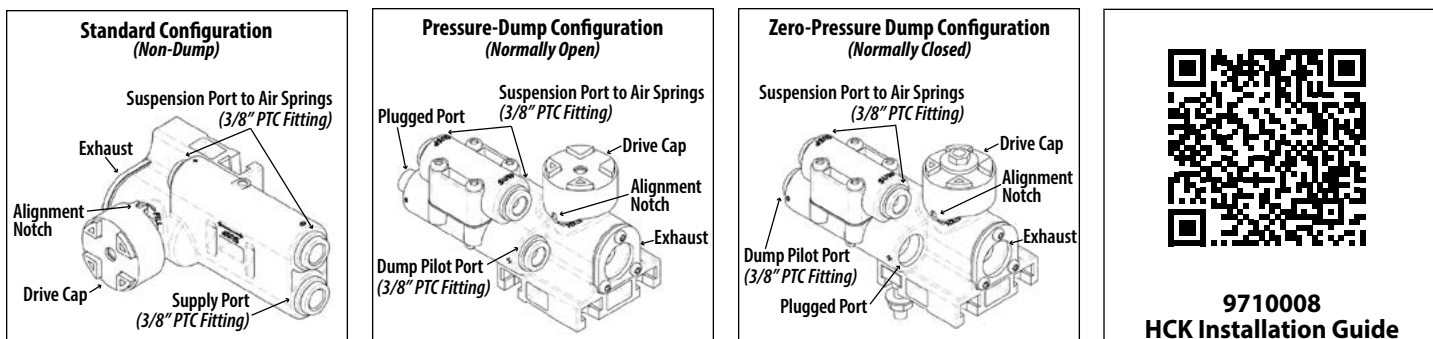

**9710008  
HCK Installation Guide**

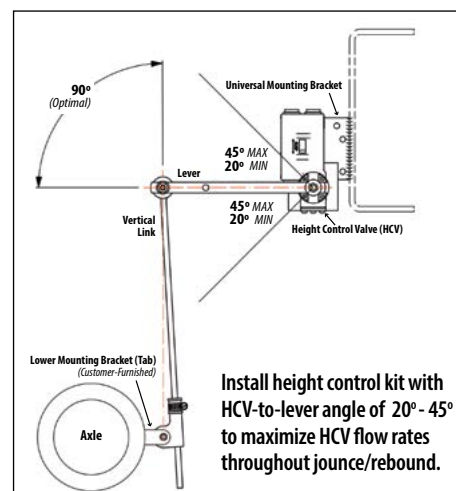
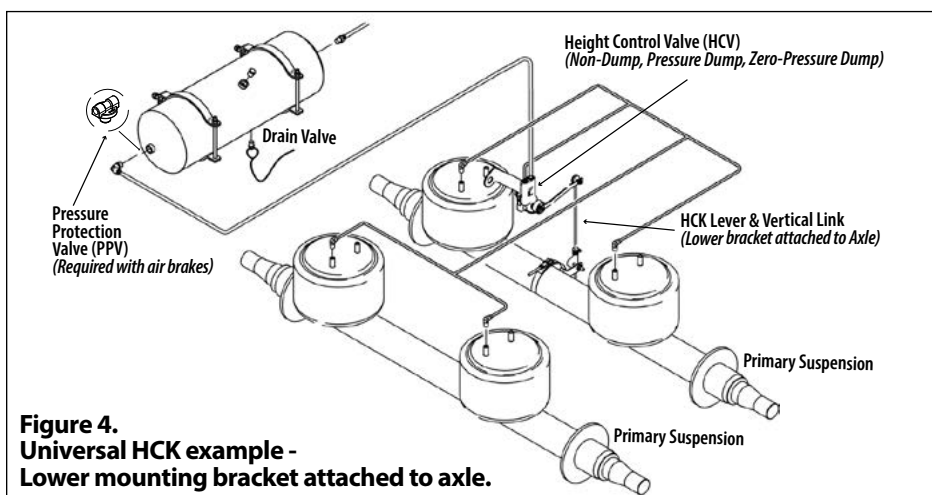

### HEIGHT CONTROL KIT – INSTALLATION TROUBLESHOOTING

Problem	Possible Cause	Corrective Action
<b>HCV is not receiving air.</b>	<ul style="list-style-type: none"> <li>Blocked air supply line.</li> </ul>	<ul style="list-style-type: none"> <li>Verify air lines are pressurized by removing supply line at HCV. Check for pinched lines.</li> </ul>
<b>HCV is not delivering air to the air springs.</b>	<ul style="list-style-type: none"> <li>Air tank not filling/reaching set pressure.</li> <li>Pressure Protection Valve (PPV) not working correctly.</li> <li>Pilot port is not plumbed or is plumbed incorrectly.</li> </ul>	<ul style="list-style-type: none"> <li>Verify air tank pressure with manual/in-line pressure gauge.</li> <li>Check PPV operation by making sure valve opens when system reaches the desired pressure setpoint (<i>usually greater than 70 psi</i>).</li> <li>Check HCV configuration and reinstall if necessary – Non-Dump; Pressure-Dump (Normally Open); Zero-Pressure Dump (Normally Closed).</li> </ul>
<b>Air springs fill but do not exhaust.</b>	<ul style="list-style-type: none"> <li>Obstructed air line.</li> <li>HCV installed backwards.</li> <li>Supply line installed to suspension port</li> </ul>	<ul style="list-style-type: none"> <li>Disconnect linkage. Rotate lever to down position (exhaust). If springs remain inflated, check for pinched/blocked lines.</li> <li>Check installation. Reinstall, if necessary.</li> <li>Move air supply line to HCV supply port.</li> </ul>
<b>Air system leaks down in a short period of time.</b>	<ul style="list-style-type: none"> <li>HCV installed backwards.</li> <li>Leak in air system beyond accepted standards.</li> </ul>	<ul style="list-style-type: none"> <li>Disconnect linkage to HCV. Turn lever to the up position (fill). If air springs do not inflate, reinstall height control valve. Check air system for leaks.</li> <li>To find leak in the HCV area, pressurize system and spray soapy water solution onto the valve and lines. Check for bubbles (leaks): No leak found – Do not remove valve, check rest of system for leaks. Check that tubing cuts are straight and smooth. Re-cut and reassemble if necessary.</li> </ul>

**Recommended Service Intervals**

Ridewell Suspensions recommends the following minimum service intervals for standard duty, on-highway usage applications. More frequent intervals are recommended for heavier duty applications.

**Daily/Pre-Trip Inspections**

- \_\_\_ Check tires for proper inflation, damage or excessive wear.
- \_\_\_ Check wheel-ends for obvious signs of lubricant leakage. Check for missing components.
- \_\_\_ Check axle assemblies for damage or loose components.
- \_\_\_ Visually inspect suspension structure for signs of damage or excessive wear.
- \_\_\_ Check for loose or missing bolts/nuts. Check for irregular movement in suspension components.
- \_\_\_ Make sure air controls are operating properly. Drain all moisture from air reservoirs.

**First 6,000 miles of use**

- \_\_\_ Torque suspension components to specifications (Page 10/Engineering Drawing).  
NOTE: Do not re-torque shear-type pivot bolt.
- \_\_\_ Verify that suspension is operating at the installed ride height.

Refer to these Technology & Maintenance Council (TMC) publications for additional information	
RP 609	Self-Adjusting/Manual Brake Adjuster Removal, Installation and Maintenance
RP 618	Wheel Bearing Adjustment Procedure
RP 619	Air System Inspection Procedure
RP 622	Wheel Seal and Bearing Removal, Installation, and Maintenance
RP 631	Wheel End Lubrication Recommendations
RP 643	Air Ride Suspension Maintenance
RP 728	Trailer Axle Maintenance

**Every 12,000 miles of use**

- \_\_\_ Inspect air springs for damage/excessive wear. Torque air spring bolts/nuts to specifications (Page 10/Engineering Drawing).
- \_\_\_ Check air lines and connections for leaks.

**Every 50,000 miles of use**

- \_\_\_ Torque suspension components to specifications (Page 10/Engineering Drawing).  
NOTE: Do not re-torque shear-type pivot bolt.

**Annually/100,000 miles of use**

- \_\_\_ Inspect pivot connection for worn pivot bushing and wear washers. Replace if necessary.
- \_\_\_ Torque component bolts/nuts to specifications (Page 10/Engineering Drawing).
- \_\_\_ Check arm beam-to-axle connection welds.

**Check lubrication level in wheel ends:**

- \_\_\_ 1) Oil-Filled Wheel Ends:  
Refill/Replace lubricant as needed (TMC RP 631-“100K/Annual Inspection”).
- \_\_\_ 2) Semi-Fluid Grease:  
Pull outer bearing and visually inspect the lubrication level. Refill/Replace as needed (TMC RP 631-“Level 3 Lubrication Level Inspection”) (TMC RP 618-“Wheel Bearing Adjustment Procedure”).
- \_\_\_ Check air lines and connections for leaks.
- \_\_\_ Test air control system pressure protection valve (PPV), if equipped.
- \_\_\_ Check height control valve (HCV) adjustment.
- \_\_\_ Verify suspension operating at installed ride height.

**CAUTION** Failure to torque suspension components to specifications can result in suspension failure and void the warranty.

**Pivot Bushing Inspection Procedure**

Park the unloaded trailer on a level surface. Set the brakes and chock the tires so vehicle cannot move during inspection.

Insert the flat end of a pry-bar between one side of the hanger sidewall and the wear washers. Move the pry-bar back-and-forth and look for excessive movement of the beam (NOTE: A small amount of beam

movement because of the rubber flexing is normal). Inspect the wear washers for excessive wear/damage.

Repeat the pry-bar process and wear washer inspection on the other side of the hanger. If any large/easy movement or damaged wear washers is observed, drop the beams for further inspection. Replace components as necessary.



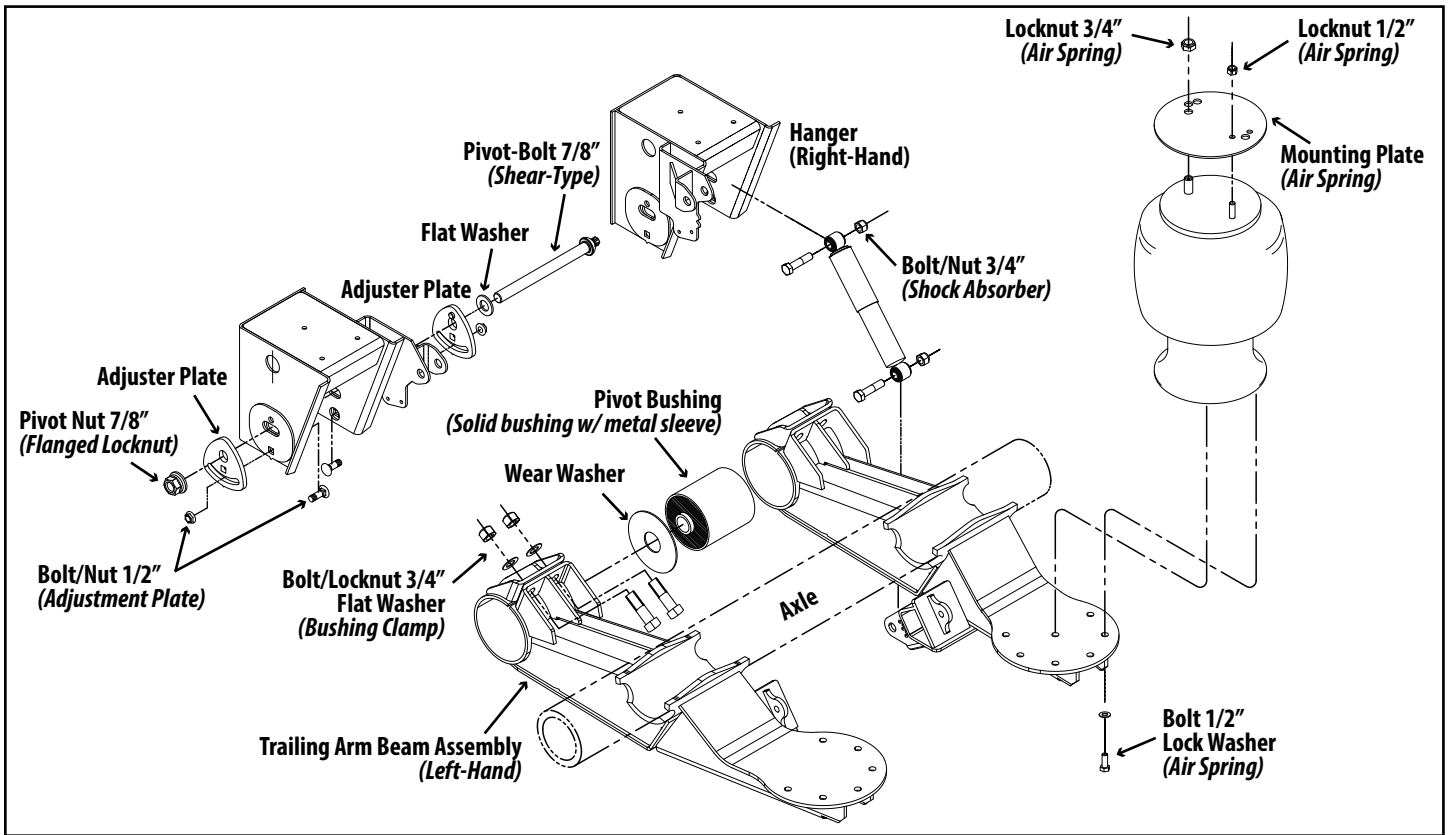

**Figure 5.**  
**RAR-243 Trailer Suspension Components**  
 Refer to the suspension model engineering drawing for the individual component part number.

## RAR 243 TRAILER SUSPENSION – BUSHING REPLACEMENT KIT

Part Number	Item Description	Size	Torque Values	
			foot-pound	Newton-meter
<b>6040064</b> <b>Bushing Replacement Kit</b>	Shear-Type Pivot-Bolt <i>Requires E-20 Torx® socket (RW #6100054)</i>	7/8"-9NC	<i>Do not lubricate bolt/nut threads. Use 1"-drive impact wrench to tighten until Torx® head shears off.</i>	
<b>Fasteners</b>	Air Spring Locknut - (Upper)	1/2"-13NC	45-50 ft-lb	61-68 N-m
	Air Spring Nut - (Upper)	3/4"-16NF	45-50 ft-lb	61-68 N-m
	Air Spring Bolt - (Lower)	1/2"-13NC	20-25 ft-lb	27-34 N-m
	Bolt/ Locknut - (Adjustment Plate)	1/2"-13NC	55-60 ft-lb	75-81 N-m
	HHCS/Locknut - (Bushing Clamp)	3/4"-10NC	280 ft-lb	380 N-m
	Locknut - (Shock Absorber)	3/4"-10NC	200-230 ft-lb	271-312 N-m

Torque values reflect a lubricated thread condition (Nuts are pre-lubed). Do not overtorque.

**CAUTION** Suspension is shipped with minimal torque applied to fasteners. All fasteners must be re-torqued after first 6,000 miles of operation. Failure to install and maintain fasteners at torque specifications could result in suspension failure and void the warranty.

### Vehicle Preparation

Park the vehicle on a level surface. Chock wheels to keep vehicle from moving.

Raise vehicle to height that removes load from suspension and support with jack stands.

Disconnect the linkage from the height control valve(s), if necessary. Exhaust all air from air springs.

**CAUTION** Failure to properly chock wheels, exhaust air system and raise and safely support the vehicle could allow vehicle/suspension movement that could result in serious injury.

### Disassemble Suspension

Remove pivot hardware. Rotate arm beams down and out of hanger.

Inspect pivot-bolt hole and hanger surfaces for wear or damage. Repair or replace components, if needed.

### Bushing Removal

Remove Huck® fasteners from bushing clamp (Figure 6). Separate bushing clamp and remove pivot bushing assembly.

NOTE: Bushing replacement kit includes traditional bolts, washers and nuts to replace Huck® fasteners used on bushing clamp.

### Bushing Installation

1. Insert new bushing assembly into bushing clamp. Install replacement bolts, washers and nuts.
2. Center bushing assembly on bushing clamp. Torque nuts on clamp to 190 ft-lb. Make sure bushing clamp surfaces are closed "metal-to-metal" and torque nuts to 280 ft-lb (380 N-m).

### Reassemble Suspension

3. Install new wear washer on inboard side of the beams. Rotate arm beams into hangers.
4. Install pivot hardware – shear-type pivot bolt, flat washer, adjuster plate, adjuster plate nut/bolt and flanged locknut.  
NOTE: Do not lubricate pivot bolt/nut. Tighten flanged locknut until pivot hardware is snug against hanger. Do not apply final torque until axle alignment has been checked (page 11).
5. Use a 1"-drive impact wrench with an E-20 Torx® socket to tighten the pivot bolt until the Torx head is sheared off.
6. Install shock absorber.
7. Install wheels and tires (if removed). Raise the vehicle and remove support stands. Lower the vehicle to the ground.
8. Connect height control valve linkage if necessary and adjust the ride height.

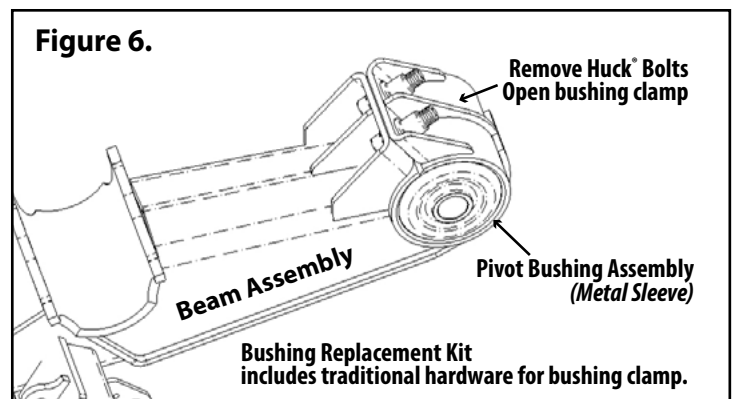

Alignment should be performed on a level surface with the suspension at the desired ride height. Align the suspension per TMC- or SAE-recommended standards.

On a multiple-axle vehicle, the forward axle is moved into proper alignment, then the remaining axles are positioned so that they are parallel to the forward axle. A maximum tolerance of 1/8-inch difference from side-to-side of the forward axle and 1/16-inch difference from side-to-side for the aft axles is acceptable (Figure 8).

The RAR 243 suspension is equipped with the Ridewell Speed Set® alignment feature for manual alignment.

### Axle alignment procedure

1. Locate adjuster plate at pivot connection. Loosen pivot and adjuster nuts enough for beam to move. Make sure that alignment pointer is at six o'clock position (Figure 7).

**CAUTION** Do not reuse pivot hardware if Torx® head is damaged or missing. A new shear-type pivot bolt, flat washer and locknut must be installed and the Torx head sheared off to complete the alignment.

2. Insert a 1/2"-shank breaker bar into the square hole of the adjuster plate. Push on breaker bar to move the beam forward or backward until the axle reaches alignment measurements (Figure 7). **NOTE:** Verify that the pivot bushing is not wedged sideways during beam movement. The adjuster plate and alignment washer should move in unison with beam movement.
3. Tighten the pivot nut so that the beam can no longer move. Re-check alignment measurements and adjust if necessary. **NOTE:** Verify both adjuster plates are flat against the hanger before final torque is applied.
4. Tighten pivot bolt with a 1"-drive impact wrench and E-20 Torx® socket (Ridewell tool #6100054) until the Torx® head is sheared off.

**CAUTION** Failure to properly torque pivot hardware could result in suspension failure/void the warranty.

### SPEED SET™ ALIGNMENT FEATURE

**NOTE:** Alignment plate must be at 6 o'clock position prior to alignment. After alignment, torque adjustment plate nut to 55-60 ft-lb.

Adjustment plates must be moved equally on both sides of hanger. Tighten shear-type pivot bolt with a 1" drive impact wrench until the Torx® head shears off from the bolt.

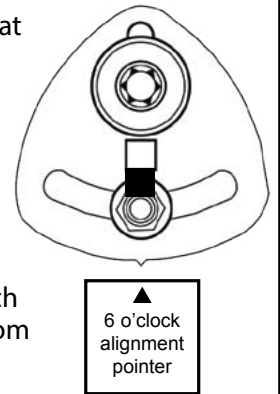

**Figure 7.**  
Alignment pointers should be at the six o'clock position before attempting alignment. Move beam back-and-forth using adjuster plate until axle reaches the desired position.

### Figure 8. Kingpin measurement for axle alignment.

Check the forward axle alignment by measuring from the kingpin to both ends of the axle centers.

If the difference between the "A" measurement and the "B" measurement is greater than 1/8-inch, the forward axle needs to be aligned.

Adjust the aft axle if the difference between the "C" measurement and the "D" measurement is greater than 1/16-inch.

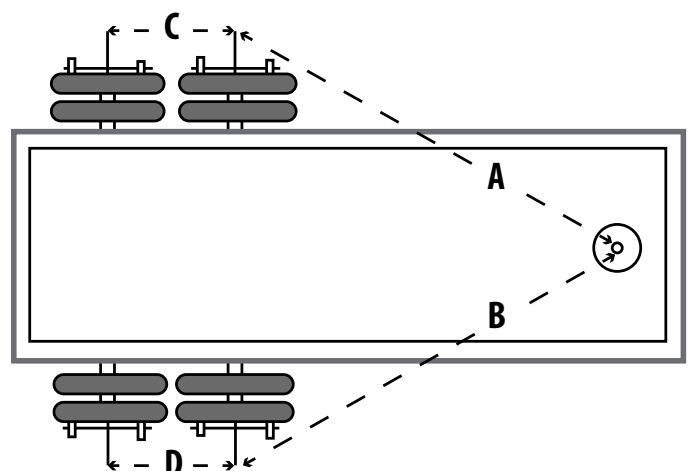

**Terms and coverage in this warranty apply only to the United States and Canada.**

Ridewell Suspensions warrants the suspension systems manufactured by it to be free of defects in material and workmanship. Warranty coverage applies only to suspensions that have been properly installed, maintained and operated within the rated capacity and recommended application of the suspension. The responsibility for warranty coverage is limited to the repair/replacement of suspension parts. The liability for coverage of purchased components is limited to the original warranty coverage extended by the manufacturer of the purchased part.

All work under warranty must have prior written approval from the Ridewell warranty department. Ridewell has the sole discretion and authority to approve or deny a claim and authorize the repair or replacement of suspension parts. All parts must be held until the warranty claim is closed.

Parts that need to be returned for warranty evaluation will be issued a Returned Materials Authorization (RMA). Parts must be returned to Ridewell with the transportation charges prepaid. The transportation charges will be reimbursed if the warranty claim is approved.

This non-transferable warranty is in lieu of all other expressed or implied warranties or representations, including any implied warranties of merchantability or fitness or any obligations on the part of Ridewell. Ridewell will not be liable for any business interruptions, loss of profits, personal injury, any costs of travel delays or for any other special, indirect, incidental or consequential losses, costs or damages.

**Contact the Ridewell Warranty Dept. at 417.833.4565 - Ext. 135, for complete warranty information.**