

Suspension Models Utilizing Wide Cavity-Bushing (6 3/4")

Primary Axle Trailer Suspension

- RAR-260 Hanger Mount – 25K/30K Capacity
- RAR-266 Overslung – 23K/25K/30K Capacity
- RAR-266 U/S (Low-Mount) – 25K Capacity

Air Ride Single Point Suspension

- RAR-254 – 50K Capacity

Notes and Cautions

This instruction uses two types of service notes definitions:

“NOTE” Provides additional instructions or procedures to complete tasks and make sure component functions properly.

CAUTION Indicates a hazardous situation or unsafe practice that could result in equipment damage and serious injury if not avoided.

Replacement Procedure – Wide Cavity-Bushing Replacement Tool (6100051)

Vehicle Preparation

Park the vehicle on a level surface. Chock wheels. Raise vehicle to a height that removes the load from the suspension. Support with jack stands.

Disconnect the linkage from the height control valve(s), if equipped. Exhaust all air from the system.

CAUTION Failure to properly chock wheels, exhaust the air system and safely support the vehicle could allow vehicle movement that results in serious injury.

Disassemble the suspension

Remove wheels and tires, if necessary. Remove the shock absorbers.

Take the pivot connections apart. Remove and discard pivot bolt, flat washer and pivot nut. Inspect the adjuster plate and the alignment washer for wear/damage. Replace if necessary.

CAUTION Do not reuse pivot hardware.

Rotate beams out of the hangers. Inspect pivot-bolt holes and hanger surfaces for unusual wear/damage. Repair or replace suspension components as needed.

Tool Assembly – Wide Cavity-Bushing Removal

Make sure thrust washer is seated firmly in the flat (outside) edge of end-cap. Examine tool cone tapered insert and large end for damage/out-of-round. Repair or replace as necessary (Figure 2).

Bushing Removal Procedure

1. Draw/scribe a line on the beam using the locator mark on installed bushing as reference (Figure 1).
2. Lubricate the hex-head bolt threads and thrust washer bearings with Extreme Pressure Lube (P/N 1980014).
NOTE: Failure to apply lubricant could result in decreased performance and reduced tool life.
3. Place flat washer onto the hex-head bolt, followed by the bearing collar, then the endcap assembly.
4. The bushing tool cone tapers inside to a smaller opening on one end. Place the larger opening of the cone onto the endcap.
NOTE: The tapered end of tool cone is placed on the eye of the beam for bushing removal/installation.
5. Insert the end of the hex bolt through the bushing sleeve into the center opening of plunger. Center cone on the beam eye. Tighten the hex bolt until plunger is held firmly against the bushing.
6. Use a 1 5/16" socket on a 3/4"-drive impact wrench (1"-drive impact wrench recommended) to rotate the hex bolt and press the bushing out of the beam eye into the tool cone.
NOTE: In some cases, a small amount of heat may be required to break the bond between the bushing and the beam eye. Do not overheat. Allow the beam to cool before installing replacement bushing.
7. Disassemble the bushing tool. Remove old bushing from the bushing tool cone and discard.

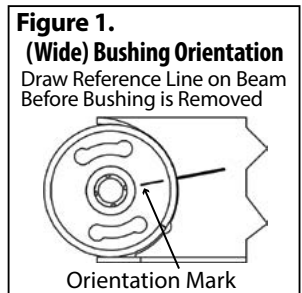

continued on next page

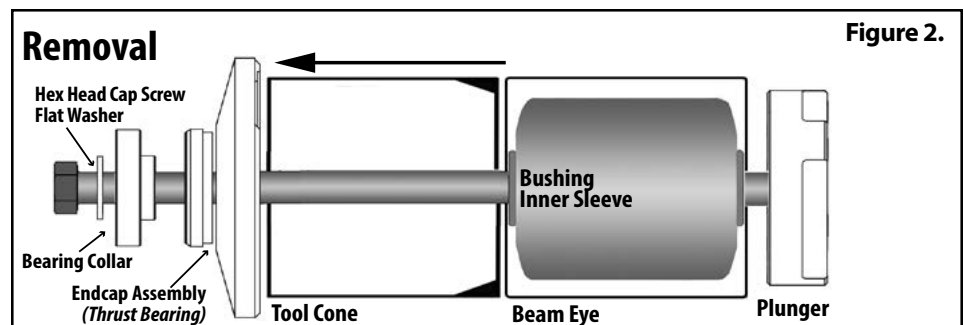

Bushing Replacement Procedure – Wide Cavity-Bushing Replacement Tool (6100051)

Tool Assembly – Wide Cavity-Bushing Installation

Place flat washer, bearing collar, and the end-cap assembly onto the hex-head bolt. Insert smooth end of the Cavity Alignment Stud (Socket Head Cap Screw-SHCS) into the four holes on the outside edge of the bushing tool plunger.

Tighten alignment stud(s) until socket head is flush with edge of plunger.

NOTE: The smooth ends of the studs should extend beyond the inside edge of the plunger (Figure 3).

Bushing Installation Procedure

1. Use a wire brush to clean foreign debris and corrosion out of the beam eye.
2. Coat the inside of the beam eye, the outside of the bushing and the inside of the tool cone with S.G. Type "M" Rubber Assembly Oil.
NOTE: Do not substitute lubricant. Type "M" Oil included with bushing kit.
3. Insert the replacement bushing into the large end of the tool cone. Make sure the locator mark on the new bushing is visible.
4. Line up the locator mark on the tool plunger with the locator mark on the bushing. Insert the four cavity alignment studs into the bushing cavity holes and press the plunger firmly against the end of the bushing (Figure 3).
NOTE: Stud threads should NOT touch bushing. Reinstall studs if necessary.
5. Align plunger locator mark with the line drawn on the beam. Place the plunger/cone/bushing assembly onto the beam eye.
6. Insert the hex-head bolt assembly through the beam eye. Thread the hex bolt into the plunger until the endcap rests against the beam.
7. Center the bushing tool cone on the beam eye. Use a 1 5/16" socket on a 3/4"-drive impact wrench (1"-drive impact wrench recommended) to rotate the hex-head cap screw and press the bushing into the beam eye.
8. Disassemble and remove the bushing replacement tool. Check placement to make sure bushing is centered in the beam.
9. Check bushing locator mark against the line drawn on beam to make sure new bushing is properly oriented.

Reassemble suspension

Rotate the beams into hangers.

Assemble the pivot connection–alignment washer, adjuster plate, wear washers, shear-type pivot bolt, flat washer and flanged locknut.

NOTE: Do not lubricate pivot bolt/nut. Tighten flanged locknut until adjuster plate pin is engaged and pivot connection hardware is snug against hanger. Do not apply final torque until axle alignment has been checked.

Connect height control valve linkage (if linkage has been disconnected). Inflate air springs.

Install wheels and tires (if removed). Raise vehicle and remove support stands. Lower vehicle to ground.

Verify suspension ride height. Check axle alignment. Realign if necessary.

Tighten pivot bolt with a 1" drive impact wrench and E-20 Torx® socket (Ridewell tool #6100054) until Torx® head is sheared off.

Install shock absorbers.

CAUTION Failure to torque hardware to specifications can result in suspension failure and void the warranty.

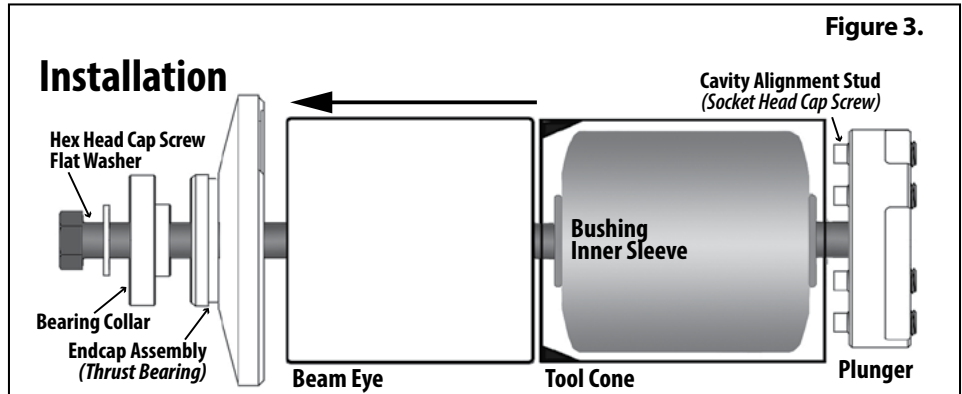

Wide Cavity-Bushing Replacement Tool #6100051

No.	Part No.	Item Description
1	1130088	Hex Head Cap Screw (HHCS)–7/8"–6 Acme; 18"
2	1160036	Flat Washer 7/8" – F436 Zinc/Coated
3	1120051	Bearing Collar – Bushing Tool
4	1660009	Thrust Bearing
5	6100086	End Cap – Wide Bushing Tool
6	6100083	Cone Assembly – Wide Bushing Tool
7	6100087	Plunger – Wide Bushing Tool
8	1130087	Cavity Alignment Stud (SHCS) 5/8" – 11x2"
—	1980014	Extreme Pressure Lubricant

