

Compressor Mounting Pattern

Wiring Diagram – ViAir A/CPSR Air Control Kit Configuration (Mounting Panel; Optional Lift/Dump Valve)

Pressure Switch/Relay Wire Designation	
Wire	TAG
Big Red	Connect to (Fused) Positive Power Source
Little Red	
White	Connect to Load or Compressor Power Wire
Black	Connect to Grounding Point (or Control Switch)

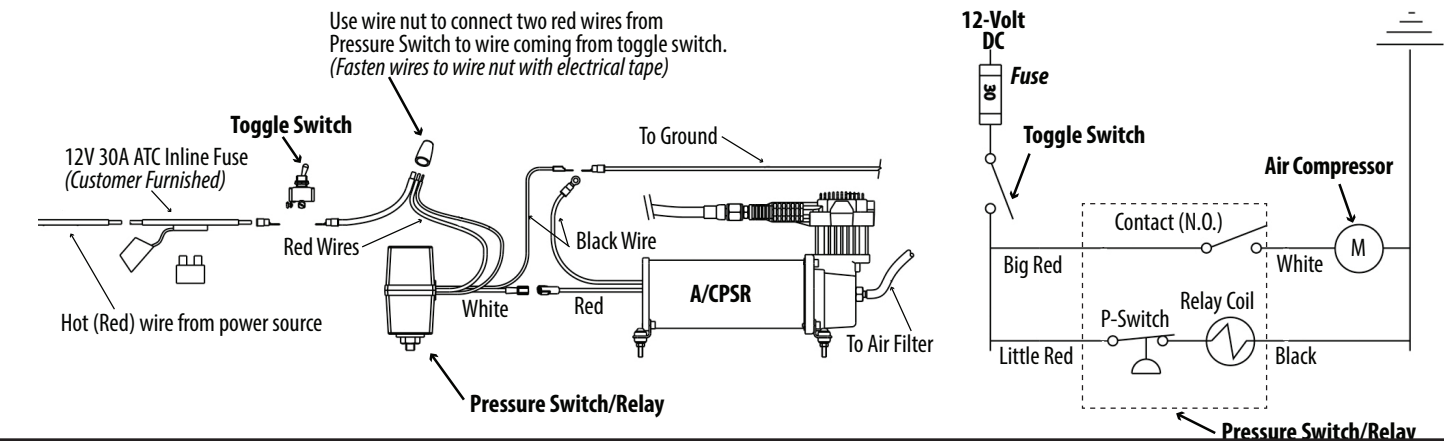

Plumbing Schematic Example: (1220019) ViAir Air Compressor Panel-Mounted ACK Configuration

- ViAir air compressor
- Air tank
- Mounting panel
- Manual Dump valve
- Pressure Gauge
- Pressure Switch/Relay
- HCK (Lo-Flo HCV)

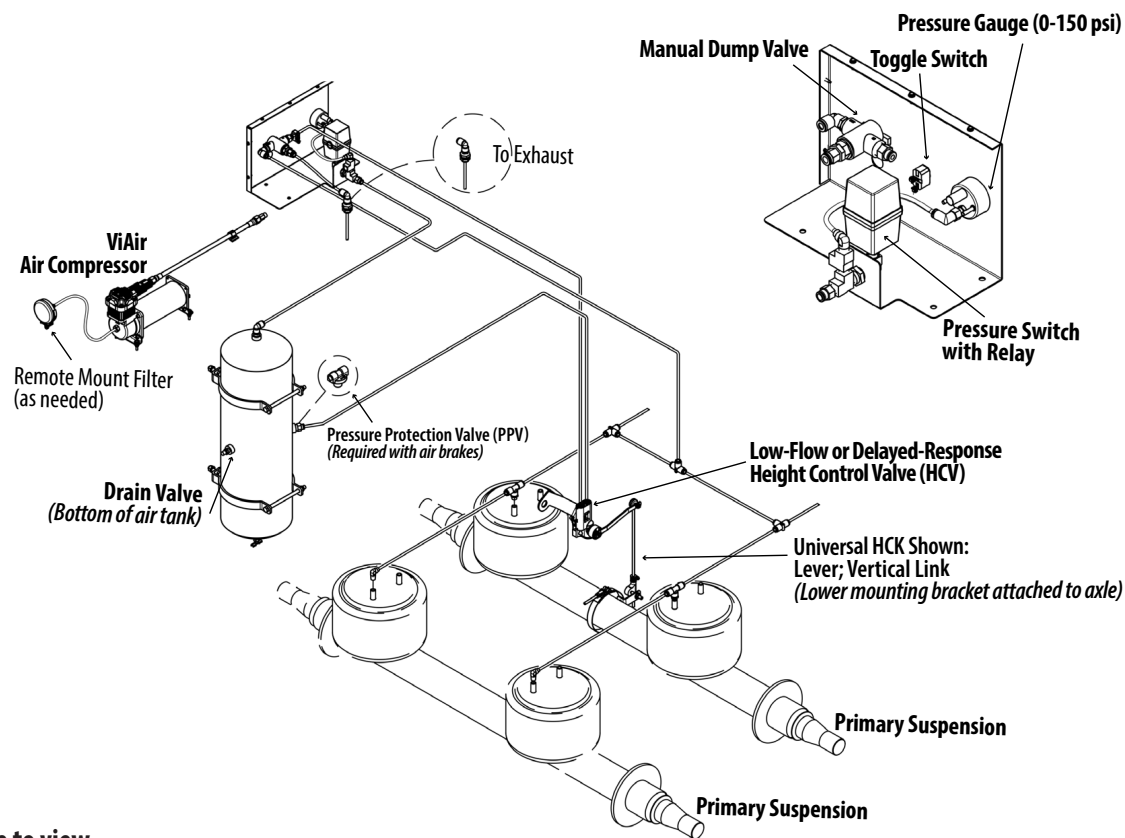

Scan QR-Code to view Air Compressor/Air Control Kit Installation and Service Manual

NOTE: Air compressor systems for air springs are not to be used with air brakes.

Air Compressor Location

Mount the compressor in a flat, secure location away from heat sources and protected from the elements. The location should provide enough air flow to cool the compressor.

Mounting Inside Enclosure

Supply at least two vent-holes when mounting the compressor inside an enclosure. Cut one hole in the side facing the vehicle front and one hole in the rear-facing side to provide enough air flow from vehicle movement to cool the compressor.

Make sure air line run lengths provide enough slack to allow for vehicle movement. Use a cutting tool instead of a knife or scissors for a clean, straight cut.

CAUTION Exhaust all pressure from the air system and wear proper eye protection at all times when working on a vehicle air system. Never touch the air compressor or connected fittings with bare hands during or immediately after use. If necessary, wear heat resistant gloves to handle the fittings, air lines, and leader hose.

Wiring

Electrical wiring should be sized according to the voltage; the maximum amperage draw of the system components; and the total wire length.

There are several wire gauge calculators online that can help determine the appropriate wire size.

Install near the battery

Locate the air compressor close to the battery to reduce the length of positive lead wire required.

Install a larger gauge positive lead wire all the way through the run when mounting the compressor away from the battery - inside the vehicle, for example.

Refer to manufacturer's specifications for the proper fuse size. Locate the fuse as close as possible to power source.

Plumb the system

Connections must be airtight to get the proper system performance. Use liquid thread sealant on all threaded air fittings. Torque fittings to 10-12 ft lbs.

Mount and plumb remote inlet air filters, if used, in a clean and dry location away from water sources. Replace the filter media when dirty.

The air tank drain should point down when mounted. The air line from the air compressor to the air tank should slope downward so that water condensation collects in the tank. Drain air tank(s) daily.

NOTE: Kinks in air lines or an upward-running air line can cause water to pool/freeze inside the lines.

The installer is responsible for making sure air system requirements comply with all federal and state regulations such as "Federal Motor Vehicle Safety Standards (FMVSS) 121 for Air Brake Systems."

Test for leaks

Connect and test the system by running the air compressor to build up pressure in the air tank. The compressor will stop when the pressure reaches the "cut-out" pressure of the pressure switch.

NOTE: Suspension system air compressors are controlled/limited by a pressure switch. The switch monitors tank pressure between a preset maximum and minimum. The air compressor turns off when pressure reaches the "cut-out level" (120-130 PSI). The compressor turns on as tank pressure drops to the "cut-in level" (90-100 PSI).

Inspect all air line connections for leaks. An air line that is not cut squarely or not pushed all the way into the fitting are the most common causes of leaks. Fix or replace air lines and air fittings as needed.



9710010-E ViAir-A_CPSR-Installation-11-22-22

UNCONTROLLED IF PRINTED

AIR COMPRESSOR OPERATION – TROUBLESHOOTING

Problem	Possible Cause	Corrective Action
Compressor will not operate	<ul style="list-style-type: none"> Power switch is in OFF position/No power to switch. Inadequate grounding. Motor overheated. Tank pressure above the air compressor cut-in pressure point. 	<ul style="list-style-type: none"> Verify battery is fully charged; Compressor switch in ON position. Disconnect compressor from power source, check for blown fuse. Replace fuse, if necessary, and reconnect. Refer to <i>Manufacturer Specification for fuse amperage.</i> Use ohm-meter to check continuity between power source and switch; from switch to compressor. Check battery/compressor grounding with voltmeter. Let compressor cool for approximately 30 minutes to allow thermal overload switch to reset. Release air pressure until compressor starts.
Fuses repeatedly burn out	<ul style="list-style-type: none"> Wrong fuse size. Electrical short to ground. 	<ul style="list-style-type: none"> Confirm fuses are proper ampere rating. Make sure battery/compressor are properly grounded.
Reset mechanism cuts out repeatedly; fuses of proper size burn out.	<ul style="list-style-type: none"> Malfunction/improperly adjusted. Lack of proper ventilation/ambient temperature too high. 	<ul style="list-style-type: none"> Adjust; repair; or replace compressor. Move compressor to well-ventilated area/area with lower ambient temperature. Drill additional holes in enclosure to vent.
Air Compressor runs continuously	<ul style="list-style-type: none"> Leak in air system beyond accepted standards. Compressor does not stop running (unload) at cut-off pressure point. Check-valve may be stuck in closed position (pressure switch was installed after check-valve). Water in air tank. 	<ul style="list-style-type: none"> Pressurize system. Spray soapy water solution onto air system fitting connections. Check for air bubbles (leaks). Re-cut/reassemble air line system. Tighten connections as necessary. Verify air tank pressure. Check that preset cut-off pressure point has been reached (± 5 PSI). Check pressure switch connections. Repair/replace pressure switch as necessary. Drain air tank. Inspect check-valve. Clean/replace parts as necessary. Drain tank.
Air flow lower than normal	<ul style="list-style-type: none"> Clogged air filter element. Low voltage 	<ul style="list-style-type: none"> Replace filter element. Verify system voltage with voltmeter.
Tank pressure drops after air compressor shuts off	<ul style="list-style-type: none"> Leak in air system beyond accepted standards. Pressure check-valve leaking. Water in air tank. 	<ul style="list-style-type: none"> Check drain valve and tighten. Spray soapy water solution onto system. Check and repair leaks as needed. Bleed tank and disassemble check-valve assembly. Clean/replace faulty parts as necessary. Drain tank.

PREVENTIVE MAINTENANCE

- Drain the moisture from all air reservoirs during each pre-trip/safety inspection.
- Air compressor power switch should be turned OFF when trailer is not in use to avoid damage to air system.
- Check the battery(ies) on a regular basis. The battery should remain at full charge (12.6 volts) at all times.
- Periodically check all electrical and air line fittings connections. Clean and tighten connections as needed.
- Replace air filter element at least once per year. Replace at least once a month if the air compressor is frequently used in a dusty environment.
- Clean dust/dirt from cooling fins and motor housing.
- Check all compressor/accessory mounting bolts on a regular basis. Tighten as needed.

Notes and Cautions

These instructions use two types of service notes: "NOTE": Provides some additional work instructions or procedures to complete tasks and ensure components function properly.

CAUTION Indicates hazardous situation/unsafe practice that, if not avoided, could result in vehicle/equipment damage and-or serious personal injury.

The Ridewell Extreme Air® Height Control Kit (HCK) adds and exhausts air from the air springs to maintain the vehicle ride height. The HCK assembly consists of a lever connected to the height control valve (HCV) and a rod arm (vertical link) connected to the HCK lower mounting bracket.

Refer to the Height Control Kit Installation Guide (P/N 9710008) for installation procedures and HCK configurations for different suspension applications. The vehicle's entire air system should be checked for leaks after any HCV/HCK installation.

CAUTION The installer is responsible for ensuring the vehicle's air system requirements comply with all appropriate Federal Motor Vehicle Safety Standards.



9710008
HCK Installation Guide

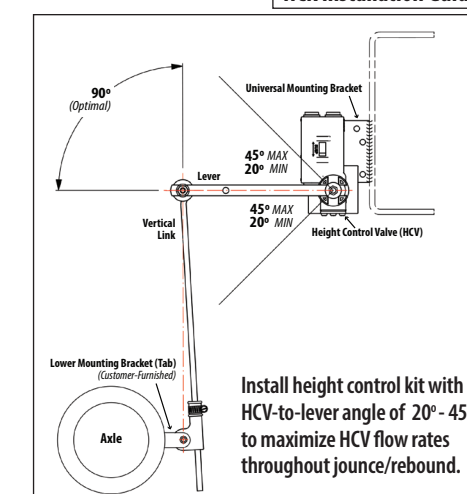
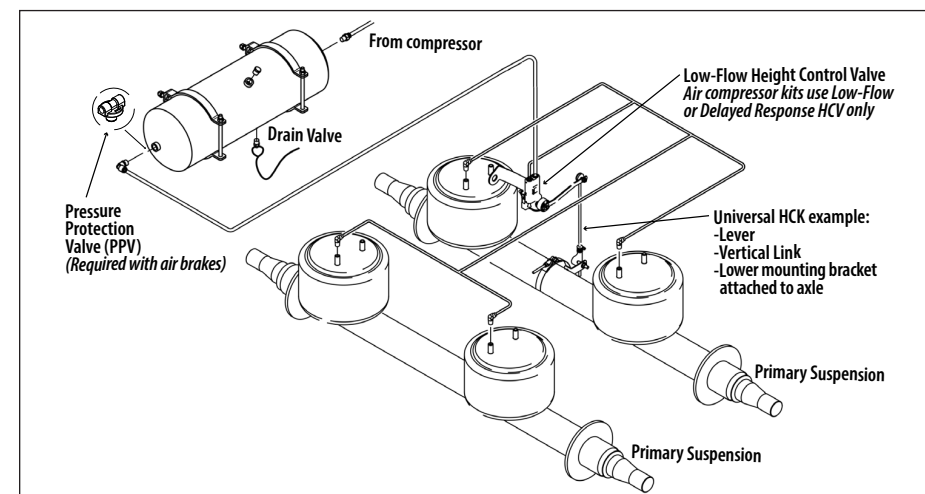

Install height control kit with HCV-to-lever angle of 20° - 45° to maximize HCV flow rates throughout jounce/rebound.

(HCV) HEIGHT CONTROL KIT INSTALLATION – TROUBLESHOOTING

Problem	Possible Cause	Corrective Action
HCV is not receiving air.	<ul style="list-style-type: none"> Blocked air supply line. 	<ul style="list-style-type: none"> Verify air lines are pressurized by removing supply line at HCV. Check for pinched lines.
HCV is not delivering air to the air springs.	<ul style="list-style-type: none"> Air tank not filling/reaching set pressure. Pressure Protection Valve (PPV) not working correctly. 	<ul style="list-style-type: none"> Verify air tank pressure with manual/in-line pressure gauge. Check PPV operation by making sure valve opens when system reaches the desired pressure setpoint (<i>usually greater than 70 psi</i>).
Air springs fill but do not exhaust.	<ul style="list-style-type: none"> Obstructed air line. HCV installed backwards. Supply line installed to suspension port 	<ul style="list-style-type: none"> Disconnect linkage. Rotate lever to down position (exhaust). If springs remain inflated, check for pinched/blocked lines. Check installation. Reinstall, if necessary. Move air supply line to HCV supply port.
Air system leaks down in a short period of time.	<ul style="list-style-type: none"> HCV installed backwards. Leak in air system beyond accepted standards. 	<ul style="list-style-type: none"> Disconnect linkage to HCV. Turn lever to the up position (fill). If air springs do not inflate, reinstall height control valve. Check air system for leaks. To find leak in the HCV area, pressurize system and spray soapy water solution onto the valve and lines. Check for bubbles (leaks): No leak found – Do not remove valve, check rest of system for leaks. Check that tubing cuts are straight and smooth. Re-cut and reassemble if necessary.